



[www.ad-maiora.eu](http://www.ad-maiora.eu)

EXTERNAL FIXATION MANUAL  
LINEAR, CIRCULAR AND HYBRID FIXATION

# INDEX

- LINEAR FIXATION:	Pag. 4
- POLILOCK FIXATOR:	Pag. 5
- TIBIA	Pag. 6
- HUMERUS	Pag. 15
- PELVIS	Pag. 19
- RAIL FIXATOR:	Pag. 23
- TIBIA	Pag. 24
- HUMERUS	Pag. 29
- DYNAMIC 2.0 FIXATOR:	Pag. 22
- RADIUS-ULNA	Pag. 37
- UNIVERSAL FIXATOR:	Pag. 45
- RADIUS-ULNA	Pag. 52
- HUMERUS	Pag. 62
- TIBIA	Pag. 66
- TRANS-ARTICULAR FRAME	Pag. 78
- BONE LENGTHENING - BONE TRANSPORT	Pag. 81
- MEASUREMENTS FOR ANGULAR DEFORMITY CORRECTION	Pag. 85

The information provided in this manual is just for orientation, and should never be considered like a technical prescription.

The external fixation instruments and frames are medical devices, and should be used only by a trained surgeon authorized to their used.

The techniques described in this manual are intellectual property of Ad Maiora srl®, and cannot be reproduced in any way without the written consent of the company.

Ad Maiora srl

Via della Costituzione 10

42025 Cavriago (RE) - Italy

<https://www.ad-maiora.eu>

[info@ad-maiora.eu](mailto:info@ad-maiora.eu)



# LINEAR FIXATION

# **POLILOCK FIXATOR**

**Mini radiolucent linear fixator**

**TIBIA**

# TECHNIQUE FOR STABILIZATION OF A DISTAL TIBIA FRACTURE BY RADIO- LUCENT LINEAR FRAME

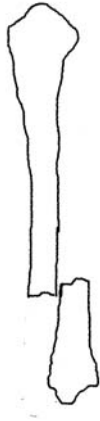

**1.** Distal tibia fracture with dislocation

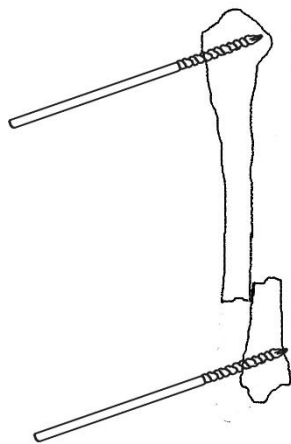

**2.** Insert a pin at the proximal end of the proximal bone segment, and at the distal end of the distal one.

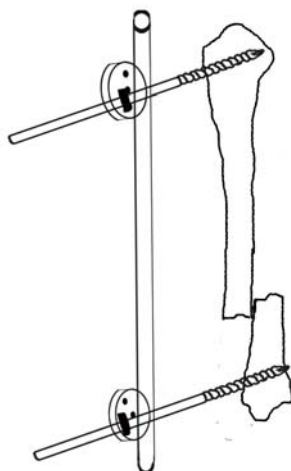

**3.** Connect the pins to clamps on a carbon connecting bar, but don't tighten them. Take care the length of the bars is enough to distract the fracture.

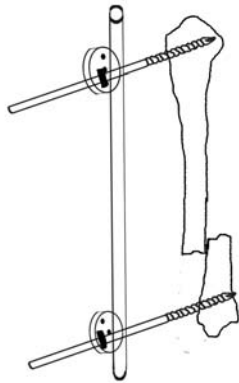

**4.** Holding the pins, apply a distraction force to the fracture area.

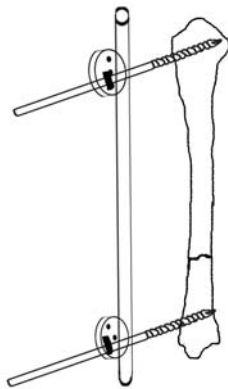

**5.** As soon as the fracture is reduced, firmly secure the pin to the clamp, in order to stabilize the fracture.

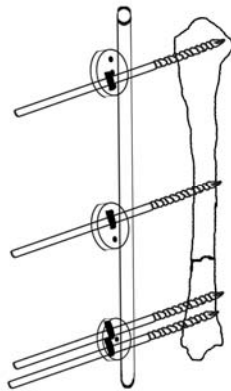

**6.** Add a second pin to the clamp in the distal fragment, and a second pin with a second clamp to the proximal one.

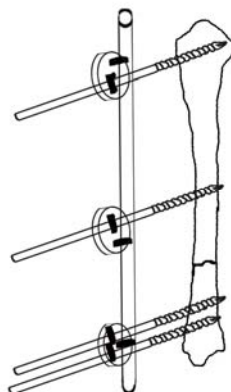

**7.** Lock each clamp to the connecting bar. Complete the stabilization as required by the fracture features.



# TECHNIQUE FOR STABILIZATION OF A DISTAL TIBIA FRACTURE BY TIE-IN RADIOLUCENT LINEAR FIXATOR

## 1. Distal tibia fracture with dislocation

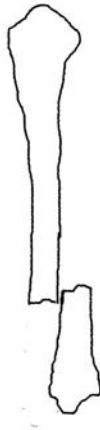

## 2. Insert a small-diameter IM pin in a retrograde fashion, starting from the distal end of the proximal fragment.

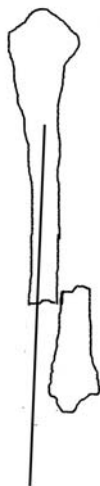

## 3. Exit the pin from the proximal tibia, and retract it from the proximal end until the distal tip is barely visible at the fracture line. Take care it doesn't exit too much, to avoid it interfering during fracture reduction.





**4.** Reduce the fracture and stabilize it inserting the pin in the distal fragment.

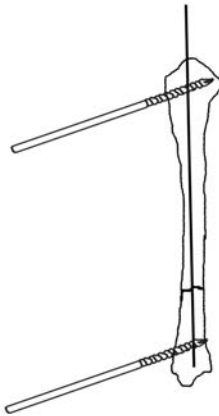

**5.** Insert a threaded pin in the most proximal and most distal area of the tibia.

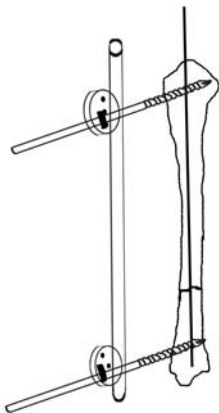

**6.** Stabilize the pins by a carbon bar and a hook each pean. DO NOT use any bar hook at this point of the procedure.

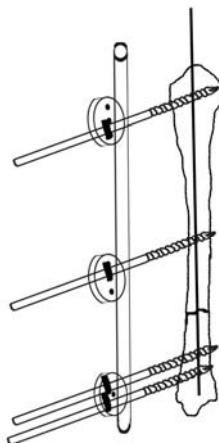

**7.** Insert one more pin in the distal part of the proximal fragment, and one in the proximal part of the distal one. The latter should be aligned to the proximal hole of the clamp.

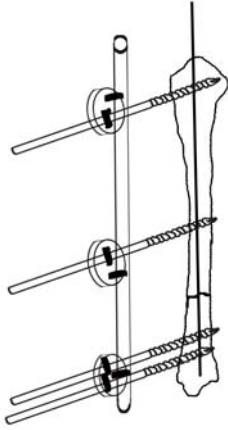

**8.** When you are satisfied with the reduction, lock the clamps to the carbon bar by means of the bar hooks.

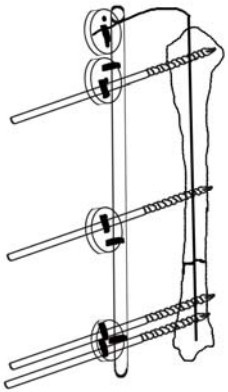

**9.** Bend the IM pin and connect it to the carbon bar by means of a clamp with a hook.

## TECHNIQUE FOR STABILIZATION OF A DISTAL TIBIA FRACTURE BY T-FRAME RADIOLUCENT LINEAR FIXATOR



**1.** Very distal tibia fracture with dislocation

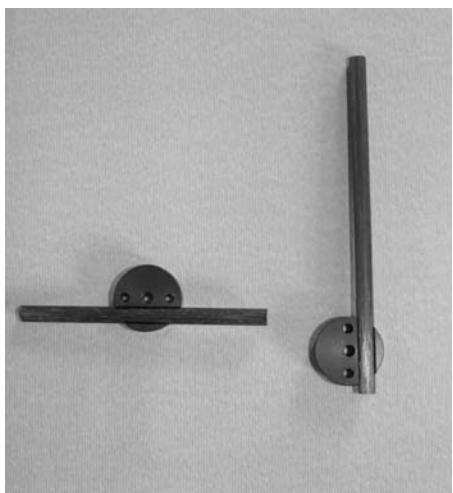

**2.** Insert a short and a longer carbon bar in the trough of each clamp with 3 aligned holes.

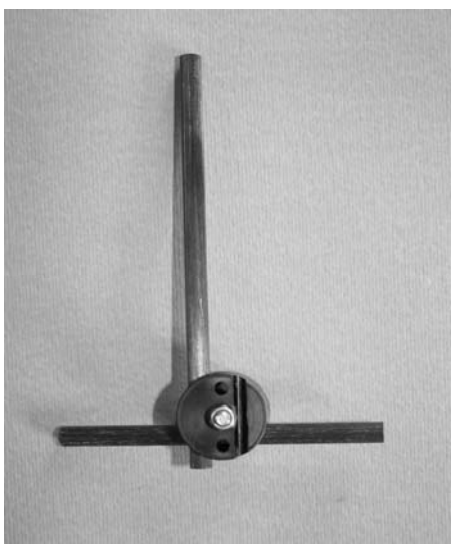

**3.** Connect the two bars tightening the double clamp by means of a M3 screw, in order to form a T frame.

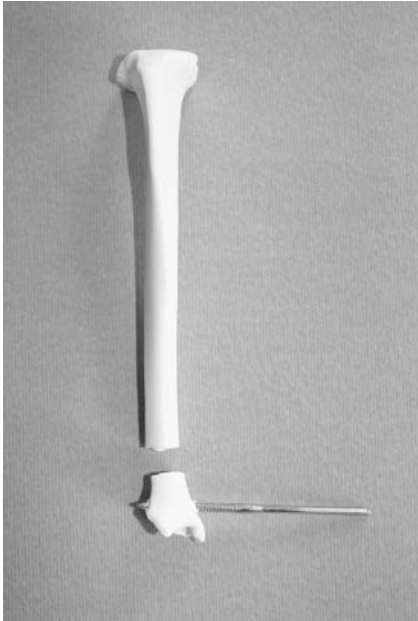

**4.** Insert a pin in the distal fragment from cranio-medial to caudo-lateral direction.



**5.** Connect the threaded pin to the shorter carbon bar by a clamp with a hook.

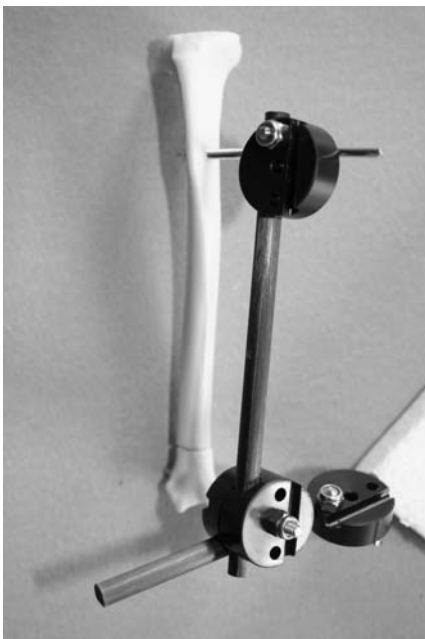

**6.** Insert a pin in the proximal fragment and stabilize the frame to the bone connecting it to the longer carbon bar by means of a clamp with a hook.



**7.** Insert one more pin in the distal fragment in a cranio-lateral to caudo-medial direction, and connect it to the shorter carbon bar by a clamp with a hook.

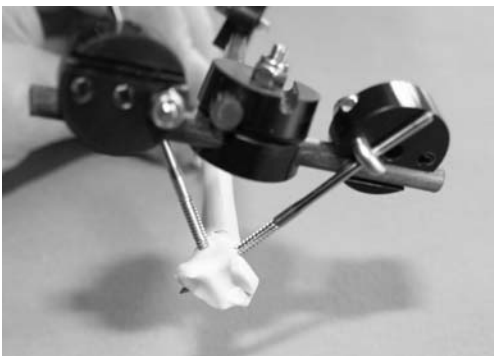

**8.** The angle between the pins is much more stable as they approach 90°.

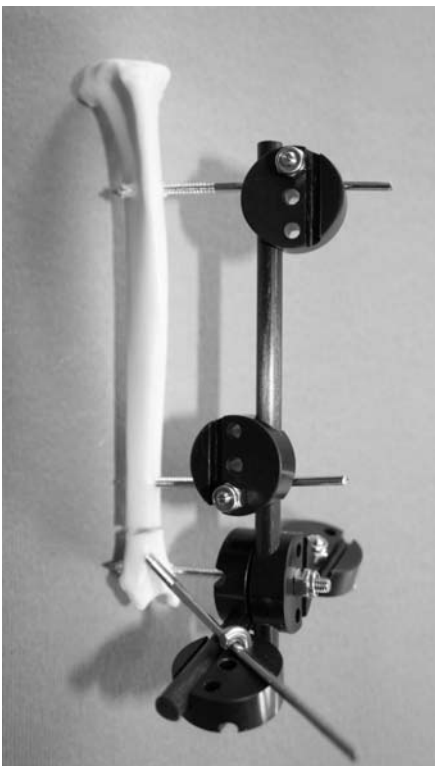

**9.** Stabilize the proximal fragment adding pins as required, and stabilizing them to the longer carbon bar.

# HUMERUS

# TECHNIQUE FOR STABILIZATION OF A HUMERAL SUPRACONDYLAR FRACTURE - TIE-IN CONSTRUCT



**1.** Examine the fracture. Usually, the distal segment is displaced medially and in recurvatus.

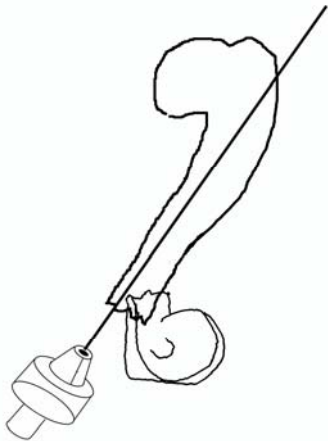

**2.** Insert a pin in a retrograde way, exiting in the proximal metaphyseal area of the humerus.

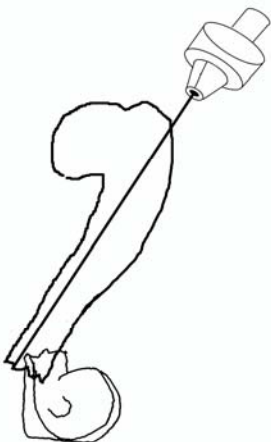

**3.** Retract the pin from the proximal side until it lies sharp with the fracture border.



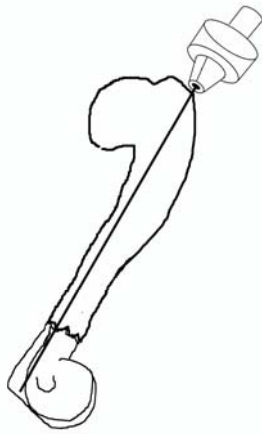

**4.** Reduce the fracture and stabilize it by inserting the pin in the medial epicondyle.

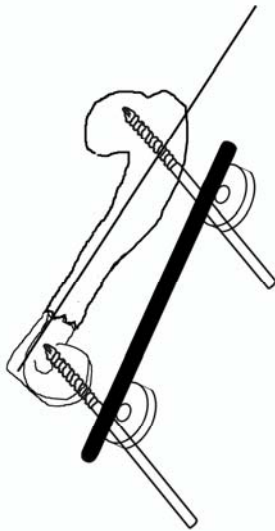

**5.** Insert one pin in the condyle and one in the proximal metaphyseal area, and connect them by a carbon bar.

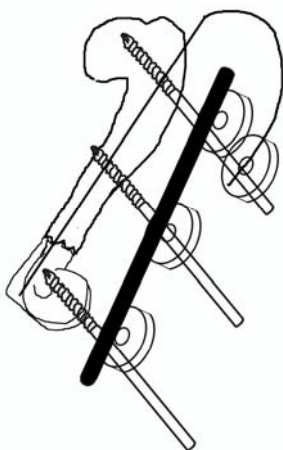

**6.** Complete the stabilization, and then connect the intramedullary pin with the proximal pin. In most cases, a single connecting bar is strong enough.

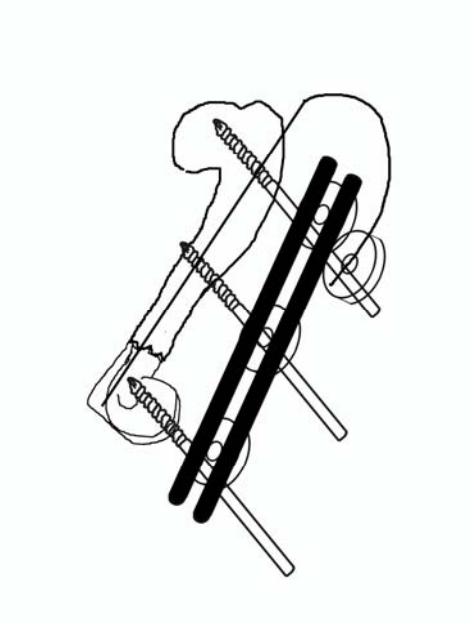

**7.** In case of a heavy or hyperactive patient, a double-bar frame construct can be used.

# PELVIS

# PELVIS FRACTURE AND ARTICULAR PROCESS OF SACRUM STABILIZATION BY LINEAR RADIO- LUCENT FIXATOR



**1.** Look at the fracture and the way it is displaced



**2.** Insert the first pin in the ilial wing of the stable hemi-pelvis.



**3.** Insert the second pin in the ischial tuberosity of the stable hemi-pelvis



**4.** Connect the two pins by a carbon bar by means of radiolucent clamps.

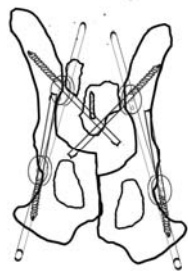

**5.** The same assembly is to be connected to the fractured hemi-pelvis, taking into account the different reference points.

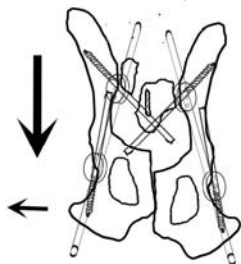

**6.** Use the frame as an handle to reduce the fracture. Usually, a caudal and abducting force is to be applied.

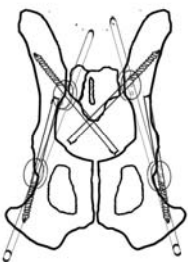

**7.** Reduce the fracture by aligning the articular process of the sacrum and the pubic symphysis. Note that disto-proximal alignment of the hemi-pelvis should be checked as well.

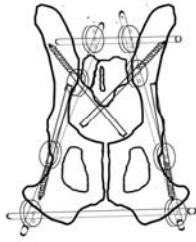

**8.** Stabilize the frame construct by connecting the caudal and cranial portions of the carbon bars by other bars. The cranial and caudal pins can be connected also.

# **RAIL FIXATOR**

**Linear radiolucent medium fixator**

# TIBLA



# TECHNIQUE FOR REDUCTION AND STABILIZATION OF A DIAPHYSEAL TIBIAL FRACTURE BY A RAIL FIXATOR



**1.** Fracture of the distal third of the tibial diaphysis



**2.** Insert a pin in each fragment close to the fracture site

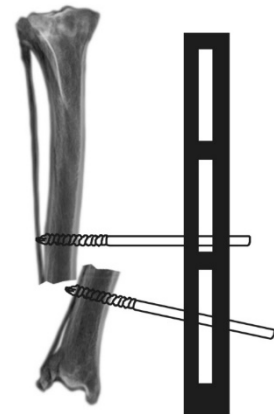

**3.** Select the rail fixator of the appropriate length

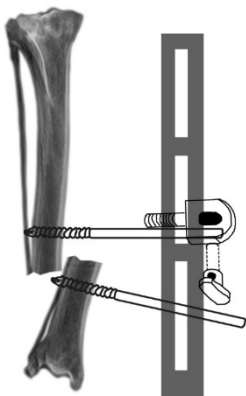

**4.** Connect the first pin to the rail by means of a post and a clamp, but don't tighten the

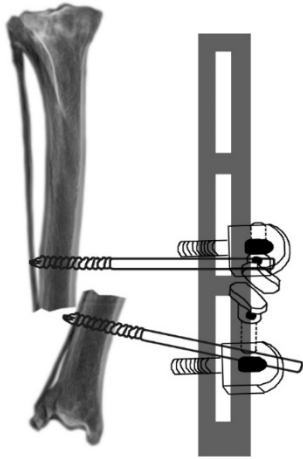

**5.** Do the same with the distal pin

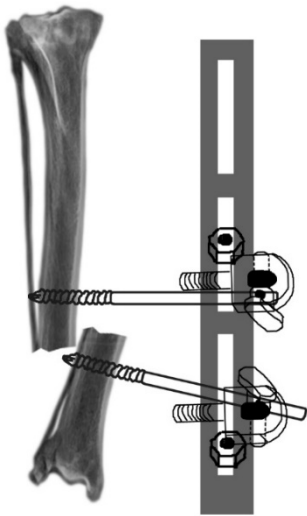

**6.** Insert and lock a bolt proximally and distally to the posts

**7.** Introduce a distractor within the two pins

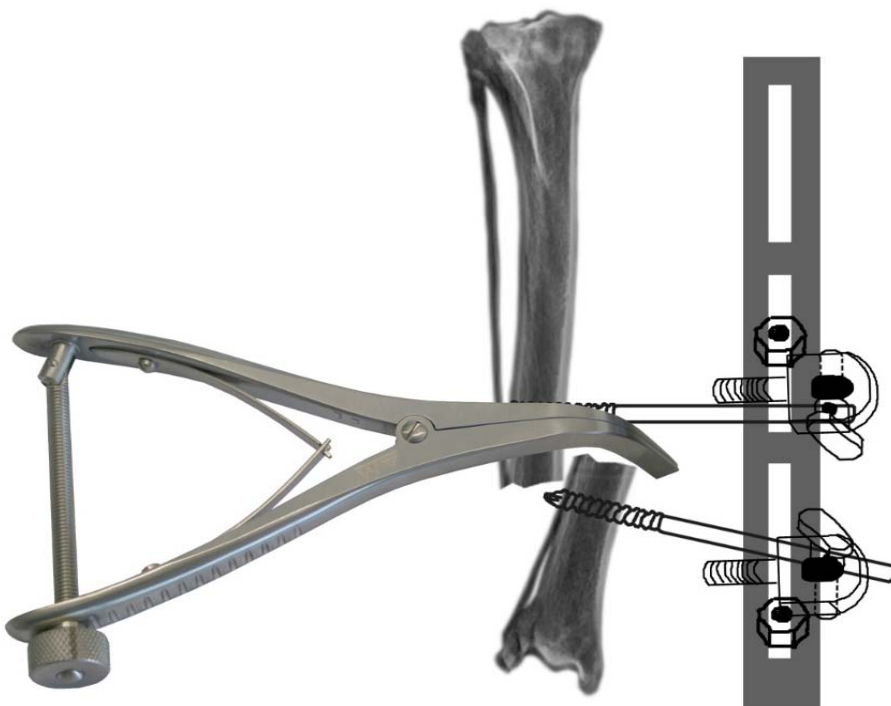

**8.** Progressively open the distractor, thus distracting the fracture until it can be reduced

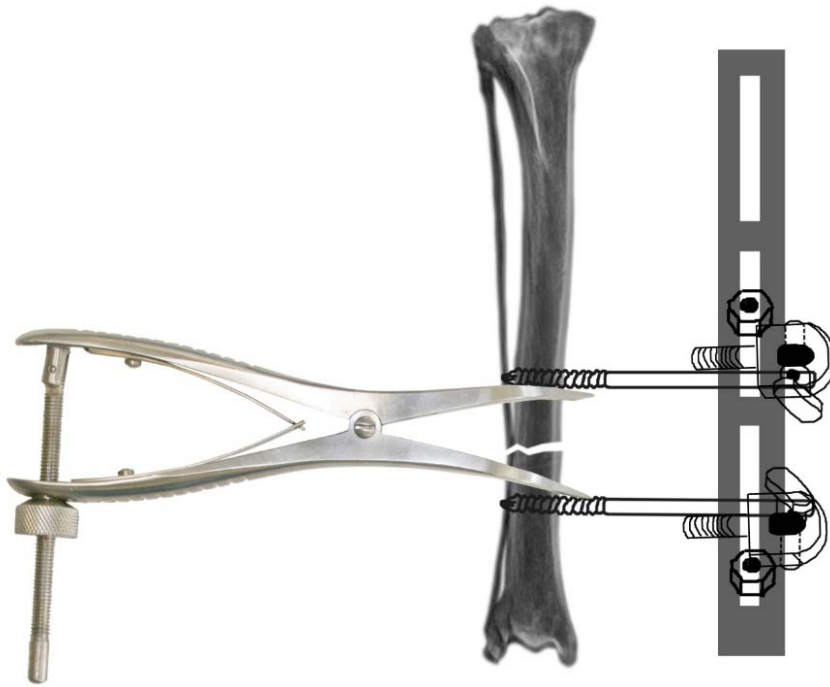

**9.** Once you're satisfied with the fracture reduction, tighten the post and clamp of both pins in order to stabilize them

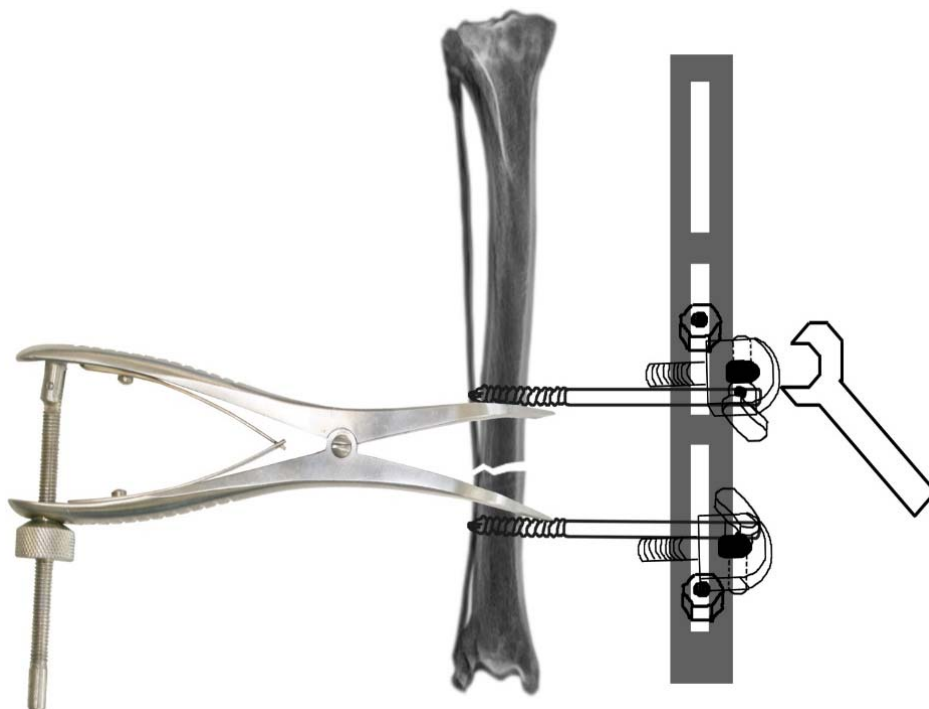

**10.** Check for the fracture reduction, and adjust it as needed

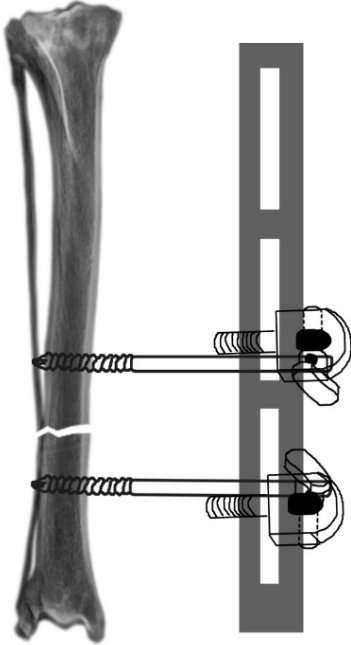

**11.** Add pins as needed for further stabilization

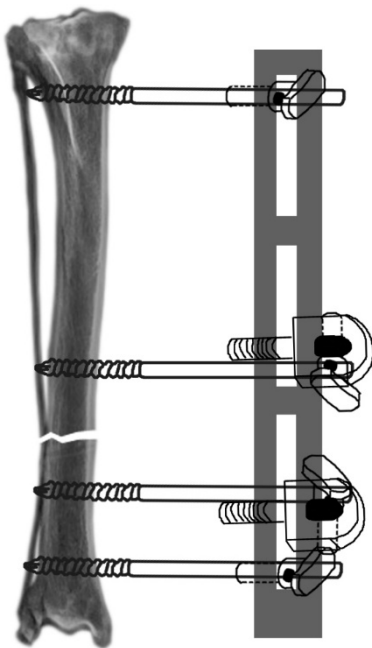

# HUMERUS

# TECHNIQUE FOR STABILIZATION OF A HUMERAL SUPRACONDYLAR FRACTURE TRIANGULAR CONSTRUCT



**1.** Examine the fracture. Usually, the distal segment is displaced medially and in recurvatus.

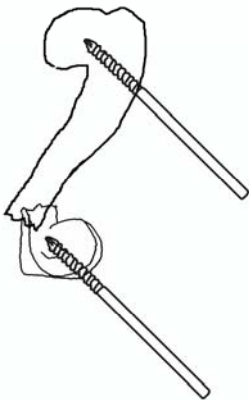

**2.** Insert a pin in each of the fracture segments. The distal one is in the condyle, the proximal one in the metaphyseal area

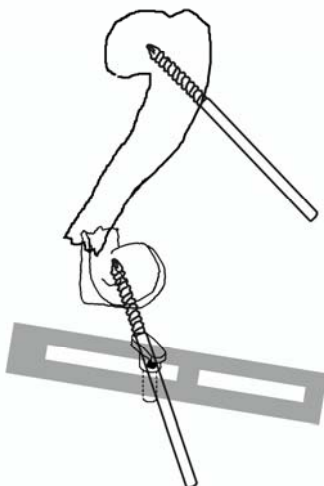

**3.** Connect the distal pin to a rail by an aluminum clamp.

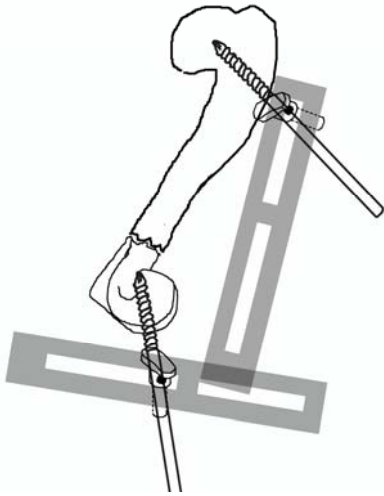

**4.** Reduce the fracture and stabilize it by connecting the proximal pin to a second rail. Connect the two rails together.

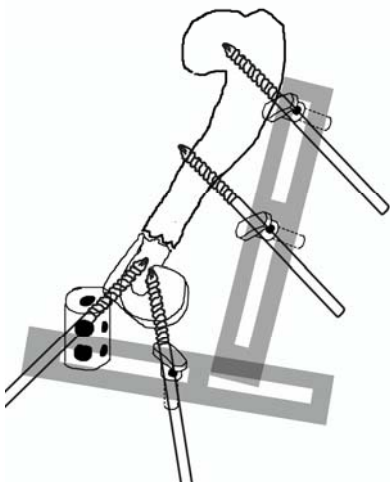

**5.** Complete the fracture stabilization as requested. Take care to avoid the unsafe area of the radial nerve.

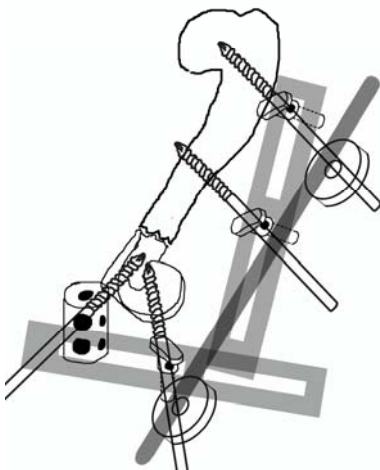

**6.** Complete the triangular frame construct by connecting the most proximal and the condylar pins by a carbon bar.

# **DYNAMIC 2.0 FIXATOR**

**Dynamizable linear external fixator**



# USE OF THE DYNAMIZABLE FIXATOR

## COMPRESSION - DISTRACTION

The fixator

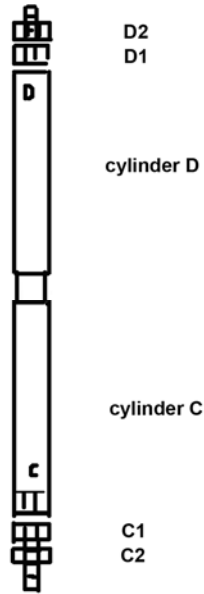

D1-D2

Nuts on the side of the D (dynamization) cylinder.

Cylinder D

The cylinder we act on to achieve dynamization.

Cylinder C

The cylinder we act on to achieve compression/distraction.

C1-C2

Nuts on the side of the C (compression/distraction) cylinder.

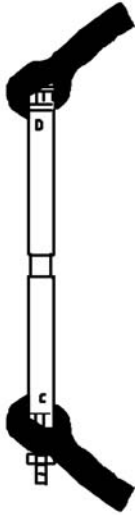

**1.** Check that the fixator is in static phase by pushing along the long axis. If not, untighten the nuts on the D side, hold the fixator stable by a wrench on the C side, and tighten the nut D1 until you feel a good resistance (NOT TOO MUCH!!)



NO

**2.** When the fixator is static, it shouldn't move along the long axis



**3.** Untighten the C1-C2 nuts, and bring them away from the C cylinder side. If you want to use the fixator for distraction, leave it as close as possible, with the C1-C2 nuts far from the C cylinder as much as possible. Tighten C1 and C2 nuts together. Do the opposite if you want to use the fixator for compression.

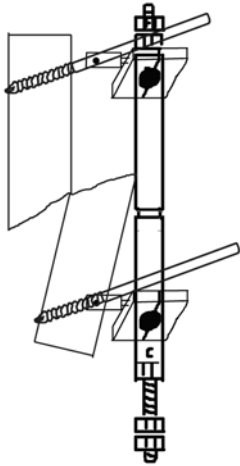

**4.** Hold the fixator by the wrench at the C side of the cylinder, and rotating clockwise the couple C1-C2 you can get distraction, or you can get compression rotating counterclockwise.

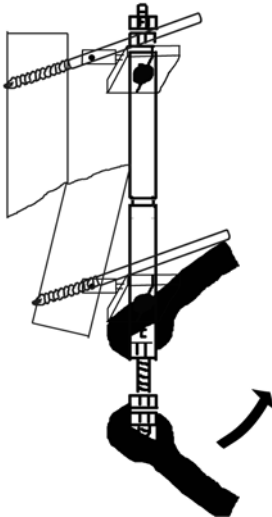

**5.** Connect the fixator to the overlapped fracture by means of two pins

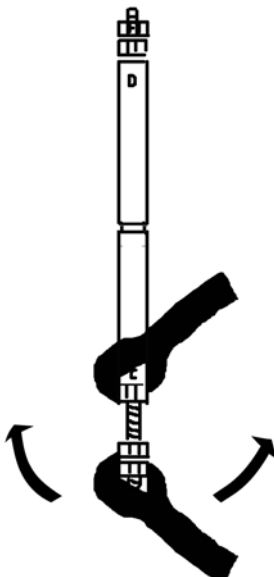

**6.** Rotate the C1-C2 couple holding the C cylinder side by means of wrenches, distracting the fracture

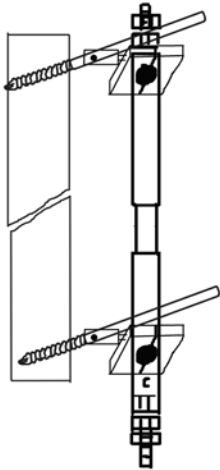

**7.** Once the fracture is distracted, check the extensions of the clamps are securely tightened (1), and use the clamp to perform the final fracture reduction on the other planes

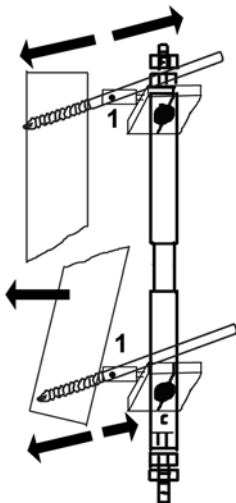

**8.** Once fracture realignment is achieved, stabilize it as required. To lock the fixator in position, tighten C1 against the C side of the cylinder, and then C2 against C1. When locked on both sides, the fixator will stay like you leave it.

## DYNAMIZATION

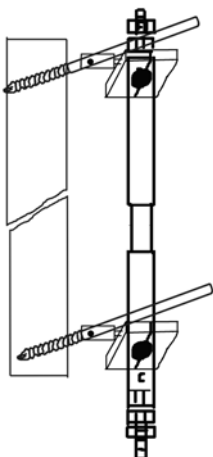

↓  
YES  
↑

Once a bone callus developed, and dynamization can be useful for its maturation, the fixator can afford for this. Untighten the D1-D2 couple on the D side of the cylinder, and move the D2 nut far from the D1 of the amount you want the fixator to allow for axial motion (typically, 2-3 mm). Then, untighten the C1-C2 couple, move it some mm far from the C side of the cylinder, and tighten it again. Rotate the C1-C2 couple counterclockwise, holding the C side of the fixator, until the D2 nut reaches the D1 nut. Lock both couples against both sides of the fixator. Once locked, the fixator will stay as you leave it (static or dynamic).

## **RADIUS-ULNA**

# RADIUS-ULNA DIAPHYSEAL FRACTURE STABILIZATION BY DINAMIZABLE FIXATOR



**1.** Look at the fracture and the way it is displaced

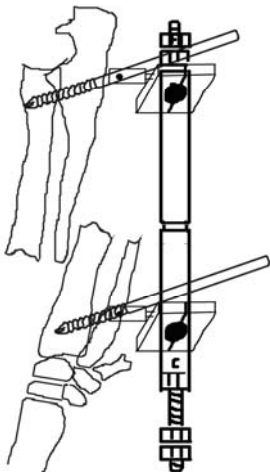

**2.** Connect the fixator to the overlapped fracture by means of two pins. Check the fixator has been connected with the cylinders close together.

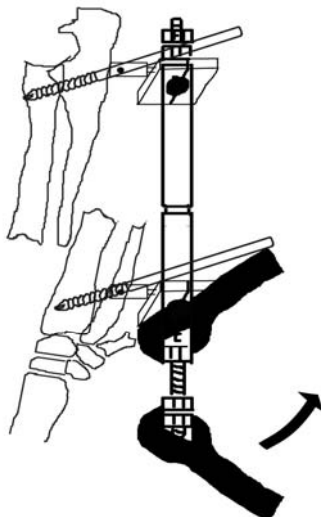

**3.** Rotate the C1-C2 couple holding the C cylinder side by means of wrenches, distracting the fracture

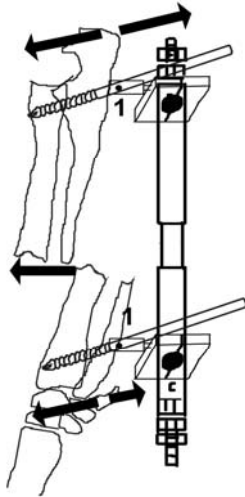

**4.** Once the fracture is distracted, check the extensions of the clamps are securely tightened (1), and use the clamp to perform the final fracture reduction on the other planes

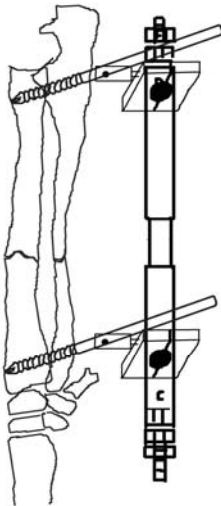

**5.** Achieve a correct fracture reduction BEFORE adding any other stabilizing element

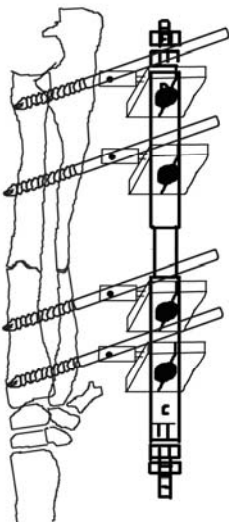

**6.** Once the correct fracture reduction is achieved, stabilize the fracture as required

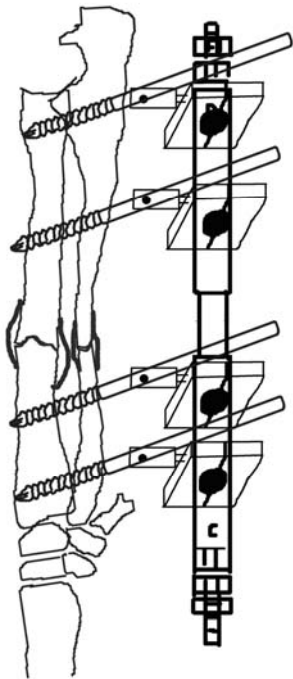

## DYNAMIZATION

Once a bone callus developed, and dynamization can be useful for its maturation, the fixator can afford for this.

Untighten the D1-D2 couple on the D side of the cylinder, and move the D2 nut far from the D1 of the amount you want the fixator to allow for axial motion (typically, 2-3 mm). Then, untighten the C1-C2 couple, move it some mm far from the C side of the cylinder, and tighten it again. Rotate the C1-C2 couple counterclockwise, holding the C side of the fixator, until the D2 nut reaches the D1 nut. Lock both couples against both sides of the fixator. Once locked, the fixator will stay as you leave it (static or dynamic).



# TECHNIQUE FOR REDUCTION AND STABILIZATION OF A DIAPHYSEAL TIBIAL FRACTURE BY A DYNAMIZABLE FIXATOR



1. Diaphyseal tibia fracture

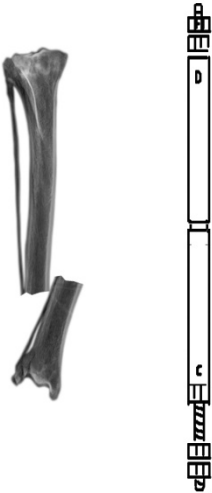

2. Select the fixator of the proper size. It should span the whole length of the tibia.

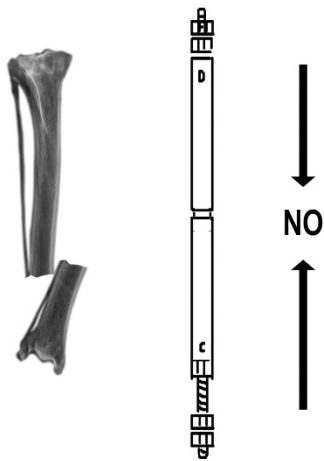

**3.** Check that the fixator is in the locked position, i.e. not dynamized. You can use it for intraop distraction only in this state.

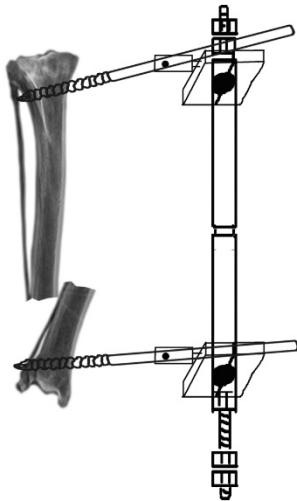

**4.** Connect the fixator to each bone stump by means of one threaded pin each, as close as possible to their proximal and distal extremity, respectively. Use clamps with the extension, in order to be able to direct the pins in every plane.

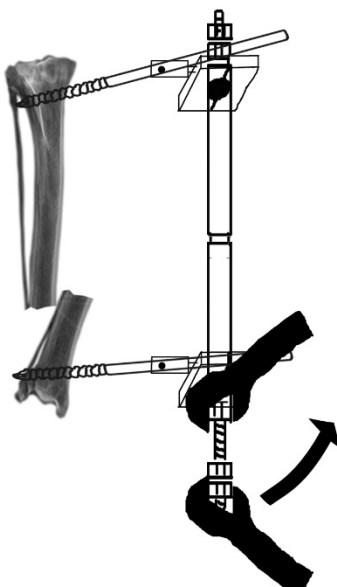

**5.** Distract the fracture by lengthening the fixator. Turn the coupled nuts on the C part of the fixator by a wrench, holding the extremity of the fixator by a second wrench.

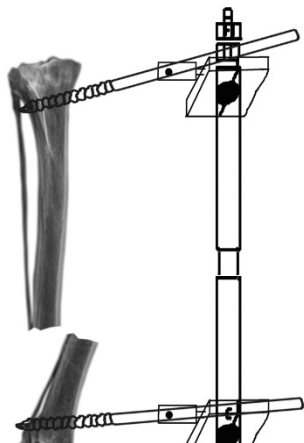

**6.** Proceed up to when the fragments are distracted so that they are no more superimposed. The fixator will lengthen during the procedure.

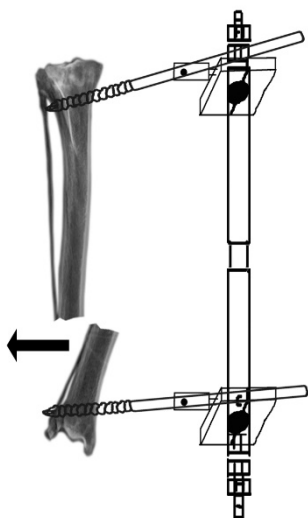

**7.** Perform the maneuvers required to correct the fragment axis and position. The clamp with extension will allow adjustments on every plane.

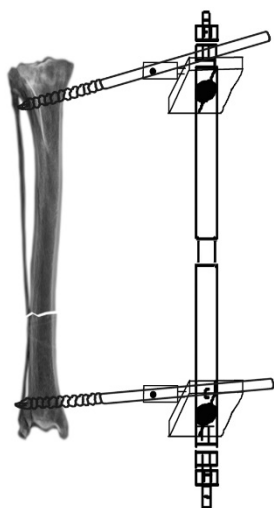

**8.** Achieve the correct fracture reduction BEFORE adding any further pin.

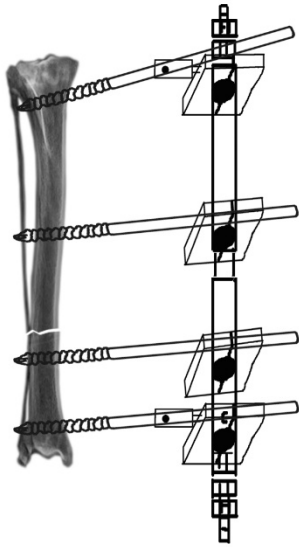

**9.** When you are satisfied with the reduction, add at least one pin to each fragment. For the intermediate pins it's not usually necessary to use extensions, but remember the pin will stay perpendicular to the fixator's axis.

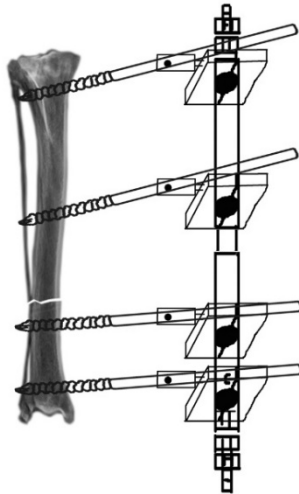

**10.** If you need to have inclined pins due to the fracture features, it's possible to use all the clamps with extensions, in order to hold them at the required angle

# **UNIVERSAL FIXATOR**

**Circular and hybrid external fixation system**

# TECHNIQUE FOR THREADED PIN CLAMPING



**1.** Insert the threaded pin through the clamp



**2.** Insert the rectangular washer (8 mm hole) below the threaded pin

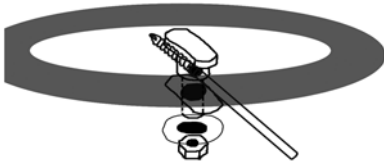

**3.** Insert the clamp with the washer through the slot in the ring

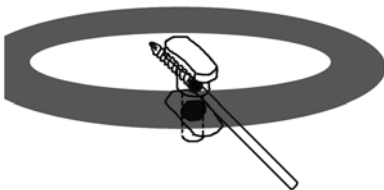

**4.** Insert the round washer and the nut on the clamp on the opposite side of the ring



**5.** Stabilize the clamp with a wrench, and tighten the nut on the opposite side

# TECHNIQUE FOR WIRE TENSIONING

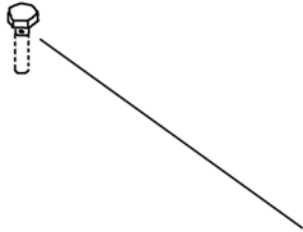

**1.** Insert the K wire through the cannulated screw on the far side of the ring

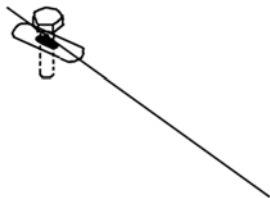

**2.** Insert the rectangular washer (5 mm hole) underneath the K wire

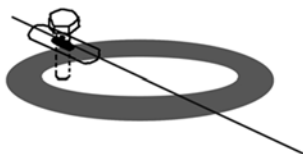

**3.** Insert the screw with the hole through the slot in the ring

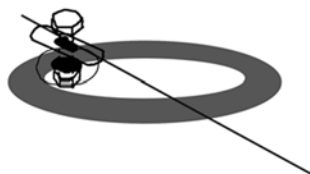

**4.** Put on the screw the round washer (5 mm hole) and the M5 nut on the opposite side of the ring

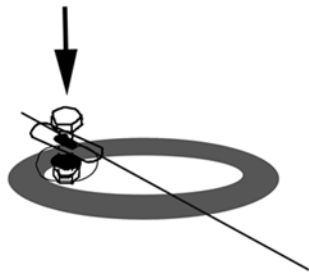

**5.** Tighten the bolt VERY FIRMLY, to avoid any K wire slippage

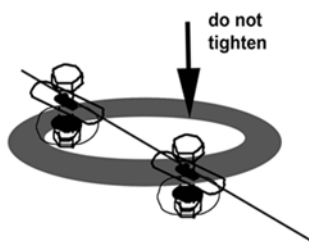

**6.** Put a second bolt on the far side of the ring, but DO NOT TIGHTEN IT

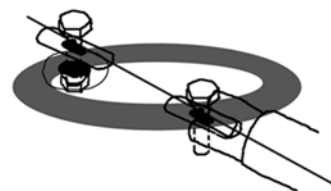

**7.** Insert the wire tensioner on the K wire, paying attention to match the head clamp to the washer

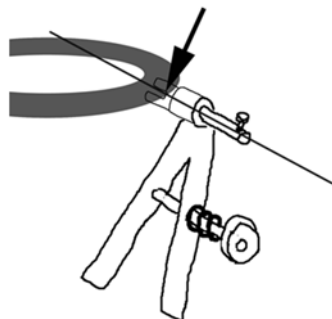

**8.** There should be no space left between the tensioner's head clamp and the ring



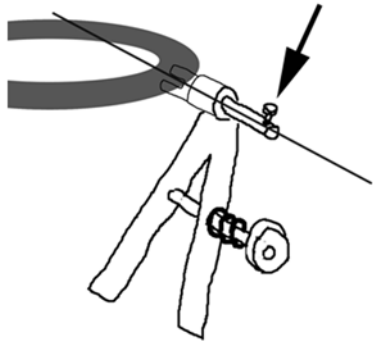

**9.** Tighten the screw on the back of the tensioner

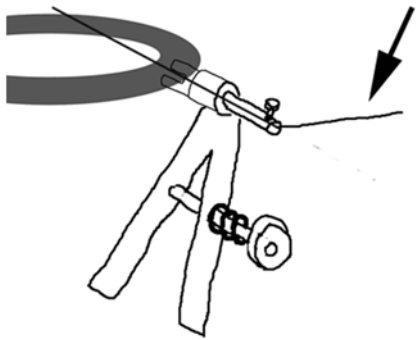

**10.** You realize when the screw is tighten enough because of the K wire bending

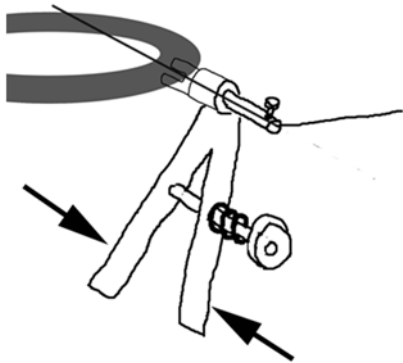

**11.** Tension the K wire pushing on the tensioner's handles

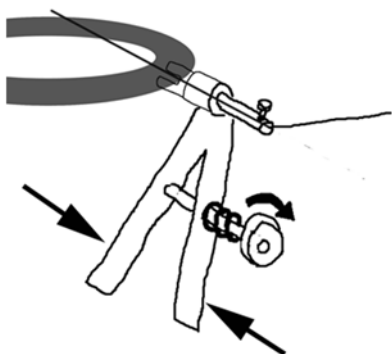

**12.** Lock the tensioner by tightening the locking nut on the side while maintaining the pressure on the handles

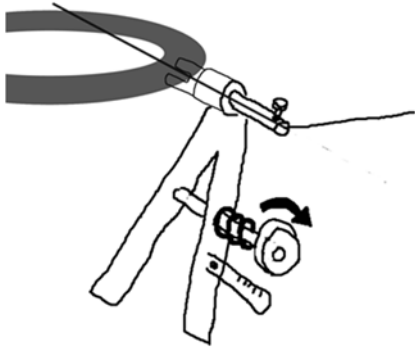

**13.** You can release pressure on the handles when the tensioner is locked, and measure the tension using the conversion chart

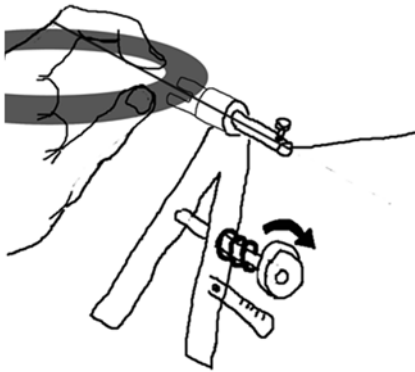

**14.** Feel the tension of the K wire by your index finger

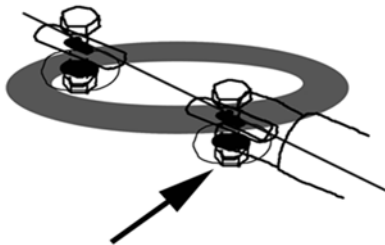

**15.** When you are satisfied with the wire's tension, tighten the nut on the near side of the ring

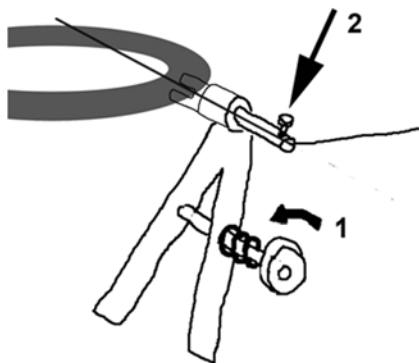

**16.** Release the locking nut on the tensioner's side, then release the screw locking the K wire

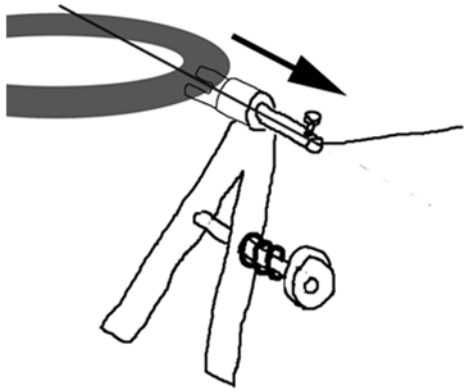

**17.** Slide the tensioner off the K wire

# RADIUS-ULNA

# TECHNIQUE FOR REDUCTION AND STABILIZATION OF A DISTAL RADIUS-ULNA FRACTURE BY MINI CIRCULAR FIXATOR

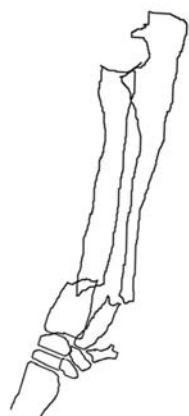

**1.** Distal radius-ulna fracture



**2.** Insert the most distal K wire and connect it with the ring

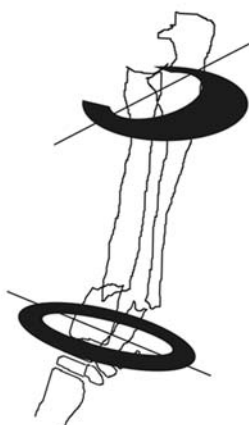

**3.** Insert the most proximal K wire and connect it with the  $\frac{3}{4}$  ring

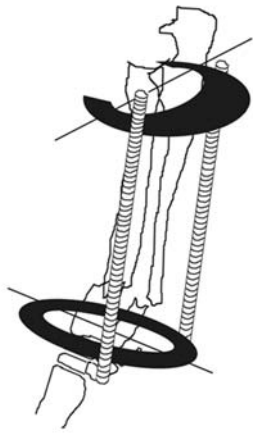

**4.** Connect the rings by means of threaded rods

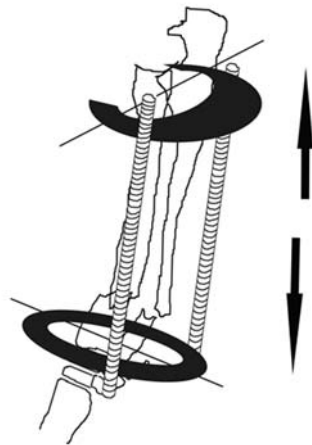

**5.** Distract the fracture acting on the nuts on the threaded bars

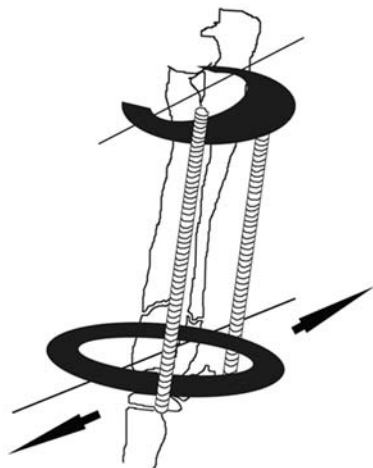

**6.** Perform the requested adjustments of the axis sliding the bone along the K wires

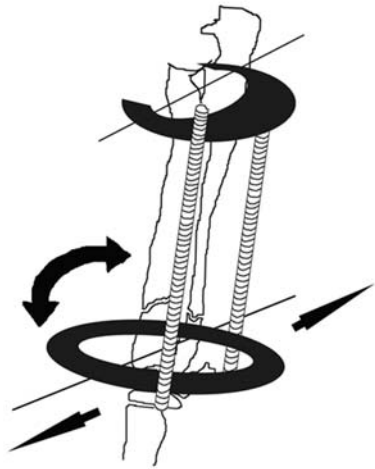

**7.** Perform the requested adjustment of torsional deformities by rotating the rings (you may require hemisphere nuts and washers for this procedure)

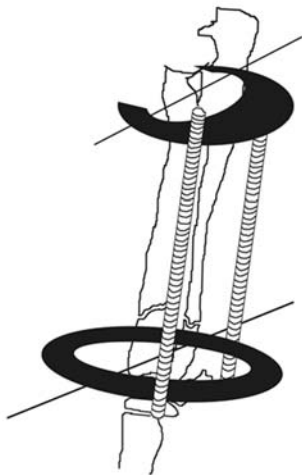

**8.** Achieve a correct clinical alignment before any further stabilization.

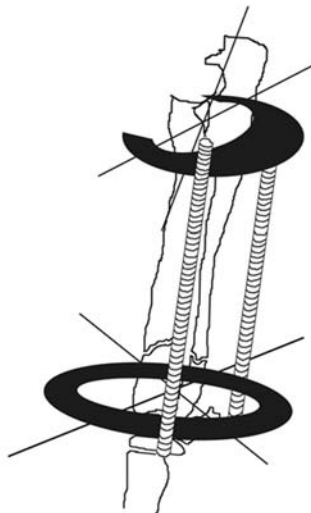

**9.** Stabilize the fragments by adding a second K-wire each

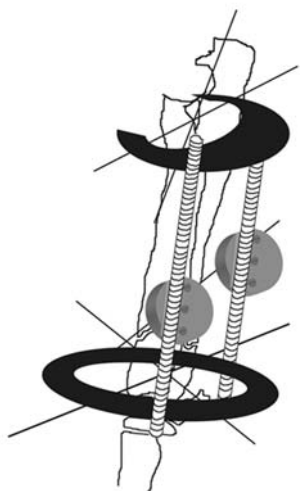

**10.** Stabilize the distal part of the proximal fragment by a K-wire hold by two radiolucent support



# TECHNIQUE FOR REDUCTION AND STABILIZATION OF A DISTAL RADIUS-ULNA FRACTURE

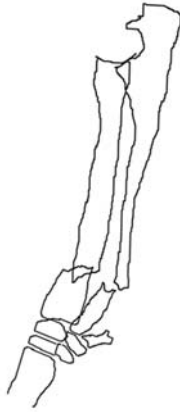

**1.** Distal radius-ulna fracture

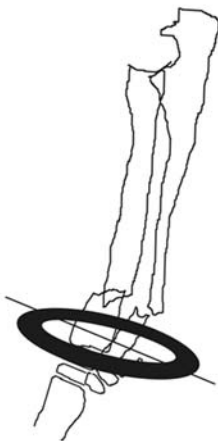

**2.** Insert the most distal K wire and connect it with the ring

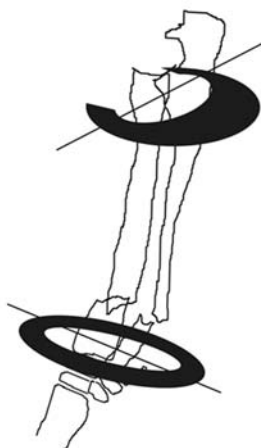

**3.** Insert the most proximal K wire and connect it with the  $\frac{3}{4}$  ring

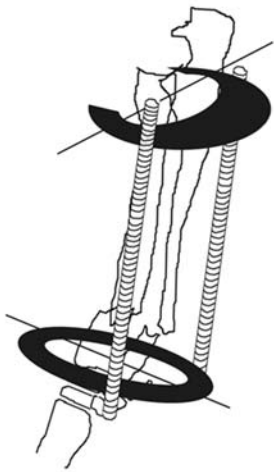

**4.** Connect the rings by means of two threaded rods with conical couple

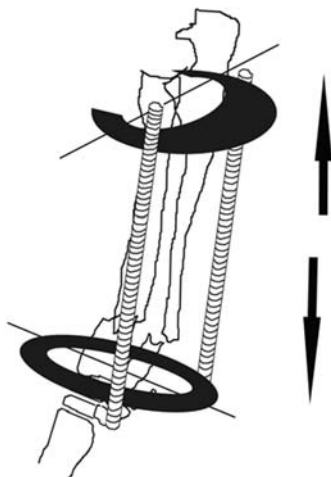

**5.** Distract the fracture acting on the nuts On the threaded bars. If needed, add a third threaded bar for reduction.

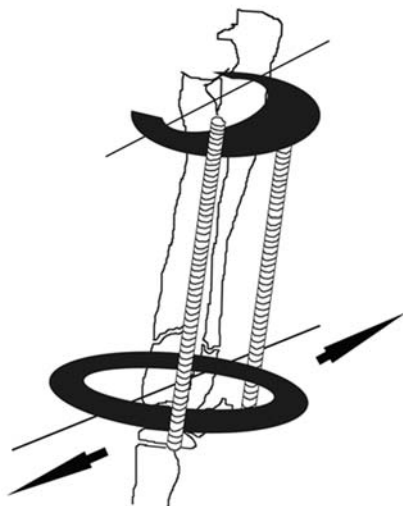

**6.** Perform the requested adjustments of the axis sliding the bone along the K wires

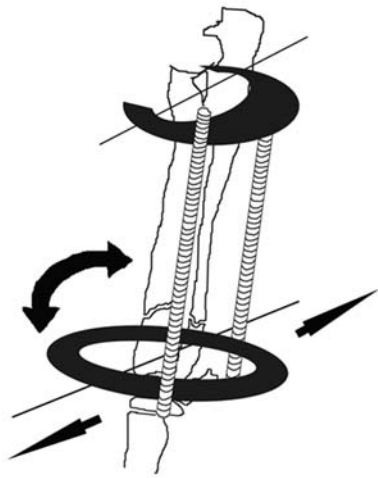

**7.** Perform the requested adjustment of torsional deformities by rotating the rings

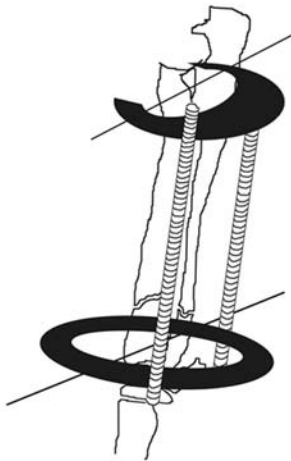

**8.** Achieve a correct clinical alignment before any further stabilization

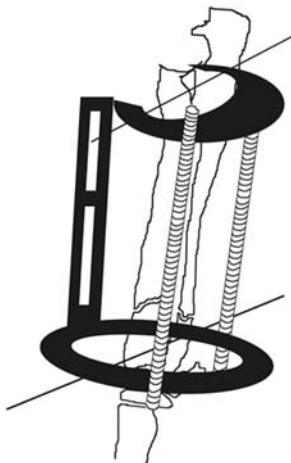

**9.** Up to this point, the circular and hybrid constructs are identical.  
If you want to set a hybrid construct up, connect a rail to the distal ring, on the cranio-medial side of the radius

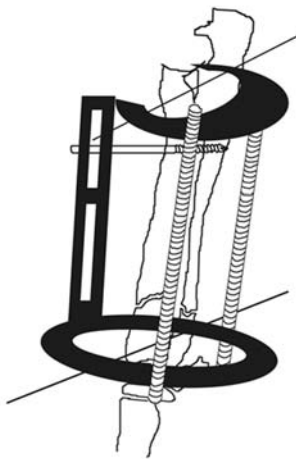

**10.** Insert a threaded pin in the radius, connecting it to the proximal slot

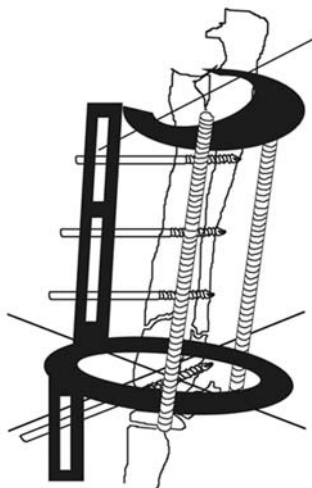

**11.** Complete the stabilization as require

Then, you have different options, based on the fracture's features and your personal preferences

**OPTION 1**

Leave at least temporarily the proximal ring for further stability, adding a K wire to it. The proximal ring may be removed after 3-4 weeks.

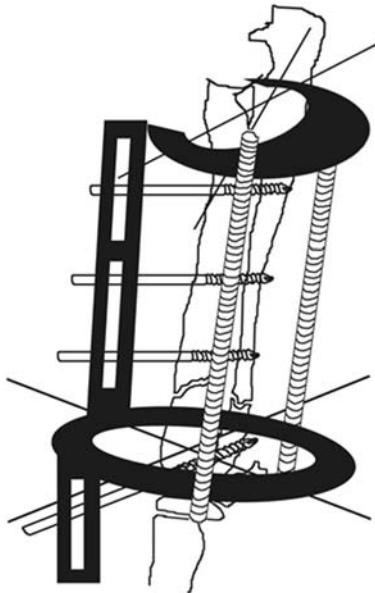

**OPTION 2**

If you think the fracture is stable enough, remove the proximal ring and threaded bars, just leaving the hybrid frame.

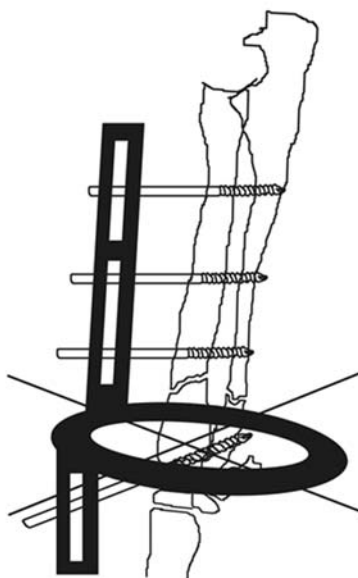

# HUMERUS

# TECHNIQUE FOR STABILIZATION OF A HUMERAL SUPRACONDYLAR FRACTURE HYBRID TRIANGULAR CONSTRUCT



**1.** Examine the fracture. Usually, the distal segment is displaced medially and in recurvatus.

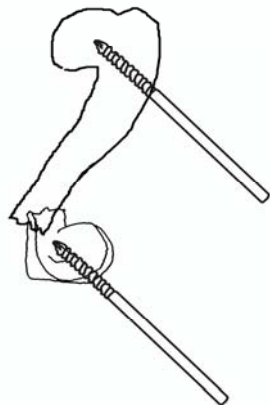

**2.** Insert a pin in each of the fracture segments. The distal one is in the condyle, the proximal one in the metaphyseal area

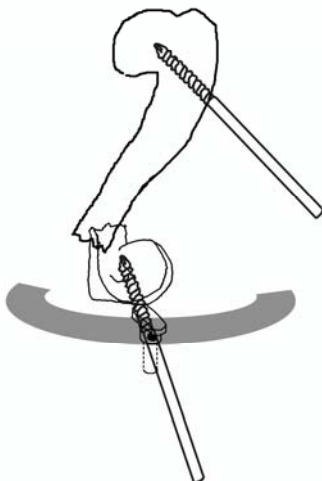

**3.** Connect the distal pin to a half ring by an aluminum clamp.

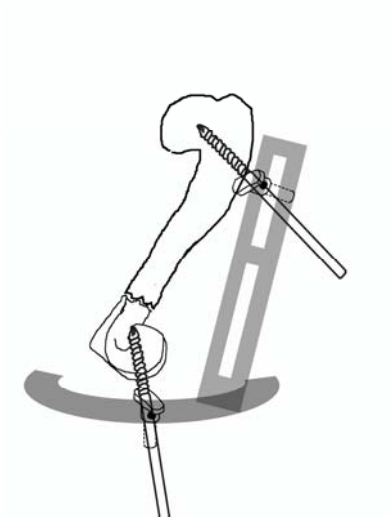

**4.** Reduce the fracture and stabilize it by connecting the proximal pin to an inclinable rail. Connect the rail to ring as required to stabilize the fracture.

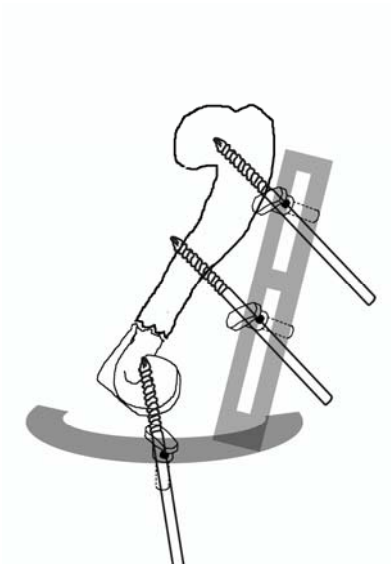

**5.** Proceed with the stabilization adding a second pin to the proximal fragment. Take care to avoid the unsafe area of the radial nerve.

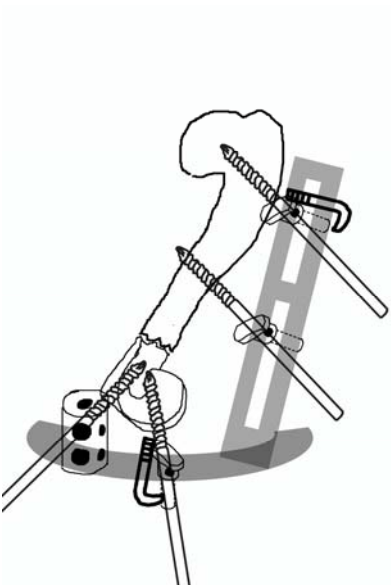

**6.** Add more pins to the epicondyles, stabilizing the distal fragment.



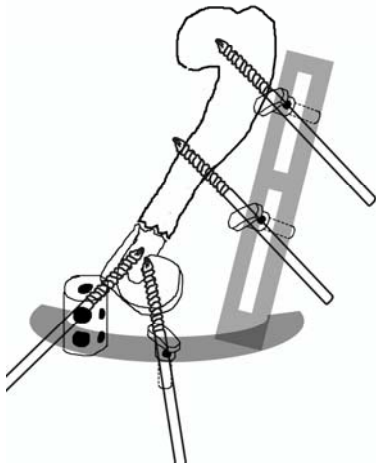

**7.** In order to further stabilize the frame structure, add hooks for strut construct using the coplanar holes in the ring and in the rail.

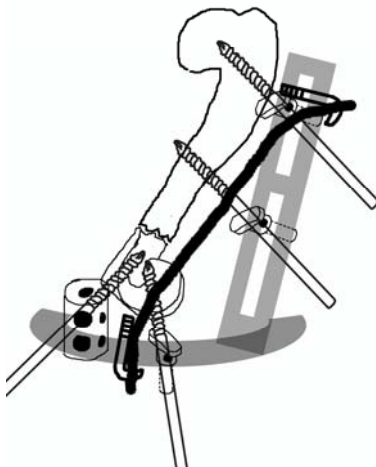

**8.** Connect a malleable stainless steel bar at its extremities to the hooks, in order to complete the strut construct, and tighten the nuts on the hooks to firmly clamp the bar.

# TIBIA

# TECHNIQUE FOR REDUCTION AND STABILIZATION OF A DISTAL TIBIA FRACTURE BY CIRCULAR FRAME



**1.** Distal tibia fracture

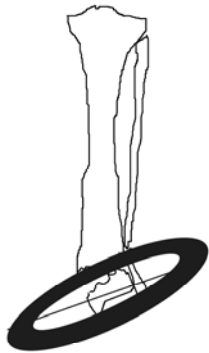

**2.** Insert a K wire parallel to the distal articular surface, and connect it to a ring

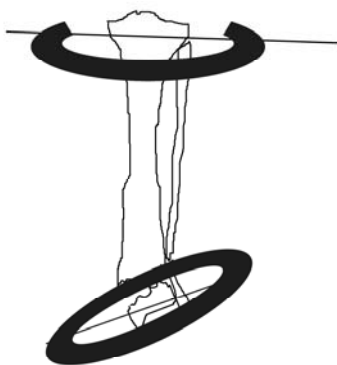

**3.** Insert a K wire parallel to the proximal articular surface, and connect it with a 3/4 ring with the opening oriented caudal

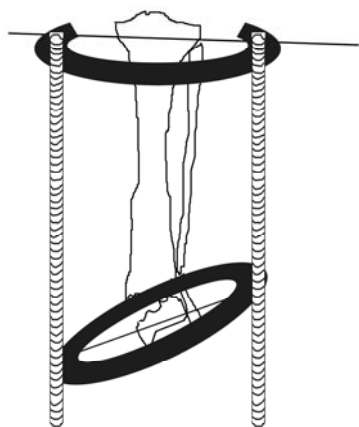

**4.** Connect the rings with threaded bars and hemispherical nuts and washers, taking care the length of the bars is enough to distract the fracture

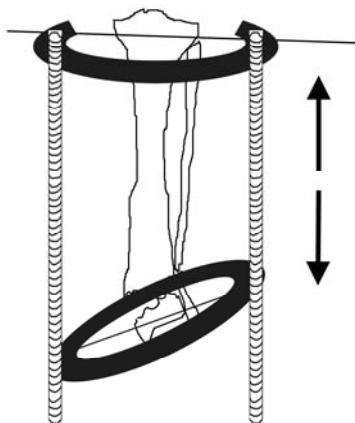

**5.** Distract the fracture by lengthening the threaded bars. Use two bars for standard distraction, three bars if the tension makes the fragment to incline

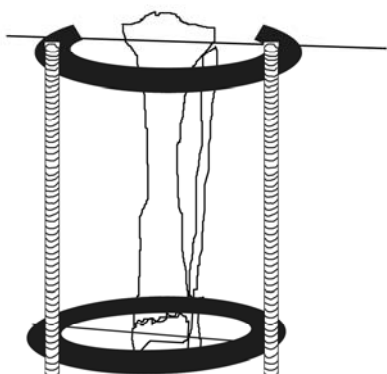

**6.** Once the fracture is distracted, correct traslational and rotational deformities to achieve the best possible fracture reduction and alignment

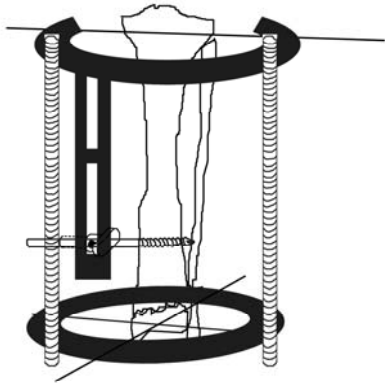

**7.** Stabilize the distal fragment by a second K wire, and the proximal one by a pin on a rail

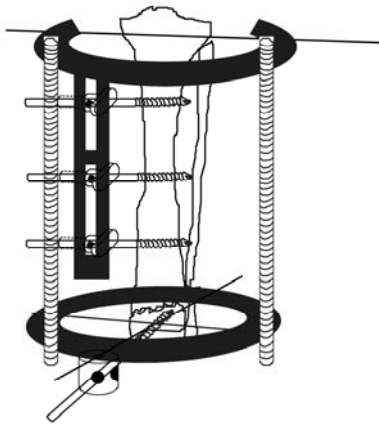

**8.** Stabilize the fracture as required

# TECHNIQUE FOR REDUCTION AND STABILIZATION OF A DISTAL TIBIA FRACTURE BY A HYBRID FRAME

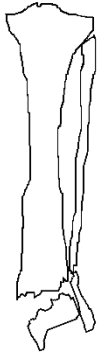

**1.** Distal tibia fracture

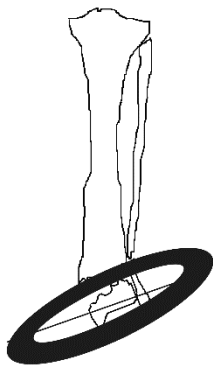

**2.** Insert a K wire parallel to the distal articular surface, and connect it to a ring

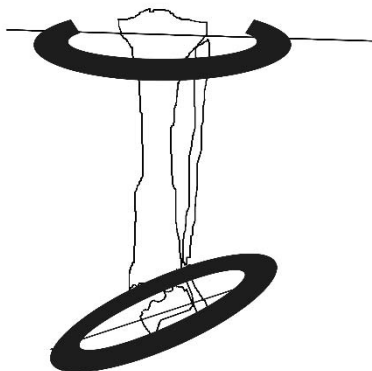

**3.** Insert a K wire parallel to the proximal articular surface, and connect it with a 3/4 ring with the opening oriented caudally

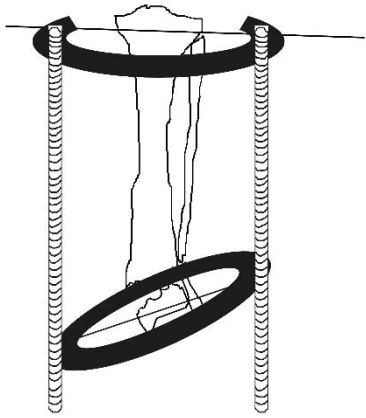

**4.** Connect the rings with threaded bars and hemispherical nuts and washers, taking care the length of the bars is enough to distract the fracture

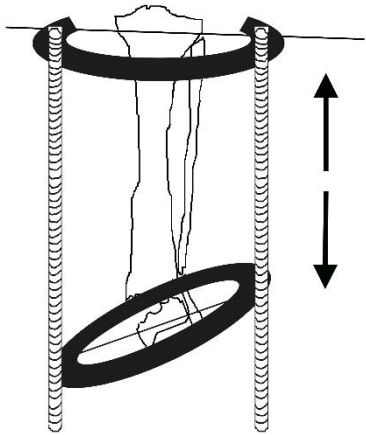

**5.** Distract the fracture by lengthening the threaded bars. Use two bars for standard distraction, three bars if the tension makes the fragment to incline

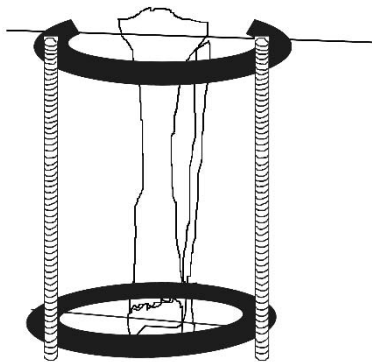

**6.** Once the fracture is distracted, correct translational and rotational deformities to achieve the best possible fracture reduction and alignment

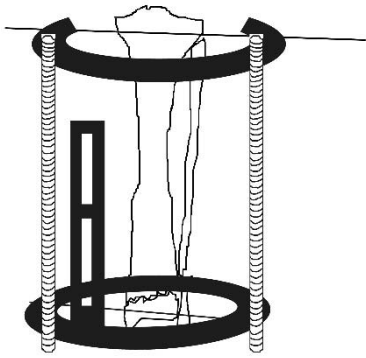

**7.** Connect a rail of adequate length to the distal ring

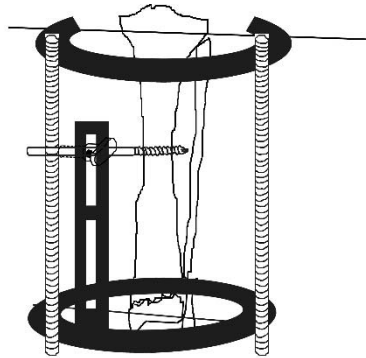

**8.** Stabilize the fracture by a pin connected to the rail

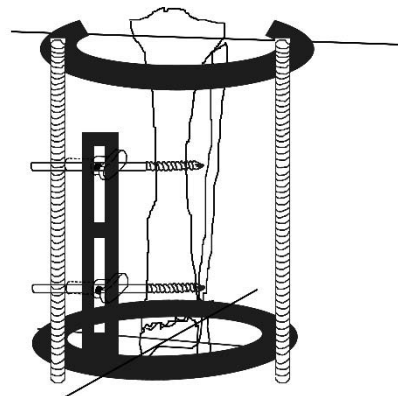

**9.** Add a K wire on the distal ring and a pin on the rail



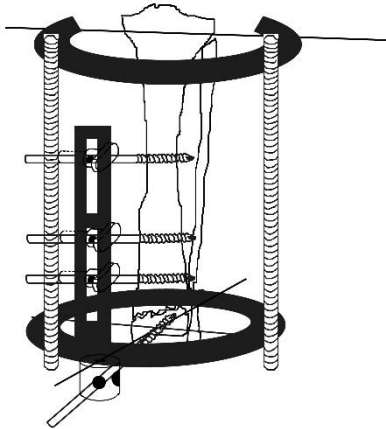

**10.** Complete the fracture stabilization adding one pin on the distal fragment and one on the proximal fragment

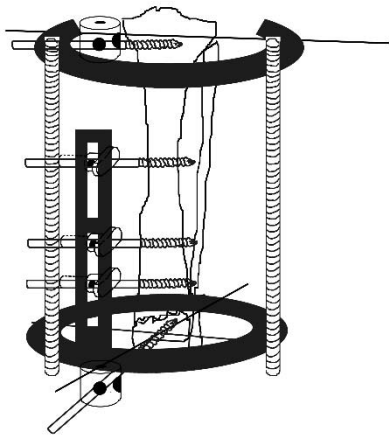

**11.** In very unstable fractures or very exuberant dogs a further pin can be added to the proximal ring, and the proximal circular component left for at least some weeks.

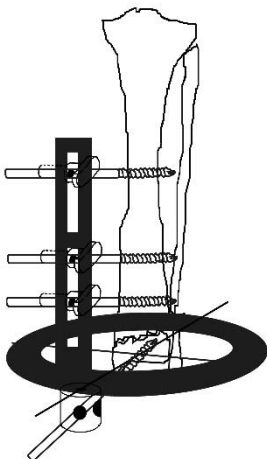

**12.** If you trust the fracture reduction and the patient, the proximal part can be removed and just the hybrid construct left.

# TECHNIQUE FOR REDUCTION AND STABILIZATION OF A PROXIMAL TIBIA FRACTURE BY HYBRID FIXATION

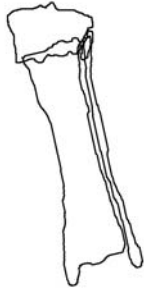

**1.** Proximal tibia fracture

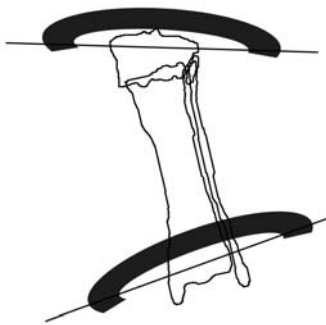

**2.** Insert a K wire parallel to each articular surface, and connect them to half rings

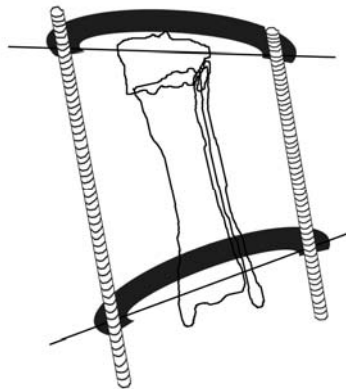

**3.** Connect the half rings with threaded bars and hemispherical nuts and washers

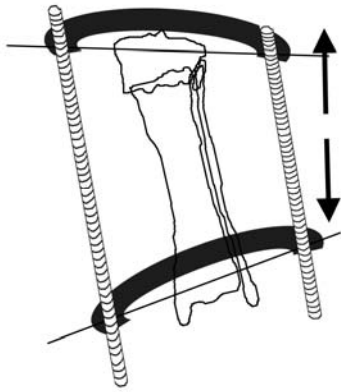

**4.** Distract the circular frame, and check the fracture overlap is reduced

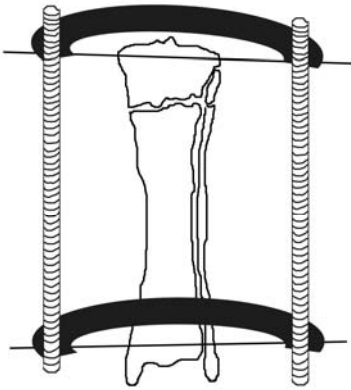

**5.** Check for fracture reduction, and correct any residual angular and torsional deformity. DO NOT any further stabilizing device before the fracture reduction is achieved.

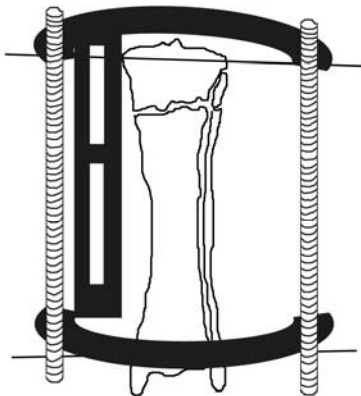

**6.** Connect a linear rail to the proximal ring in cranio-medial position to the tibia

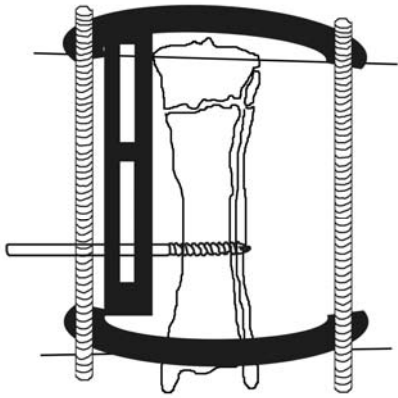

**7.** Stabilize the fracture by a threaded pin in a cranio-medial direction in the distal fracture segment connected to the rail in the distal slot of the rail. Careful: NOT at the extremity of the slot, allowing for further adjustments

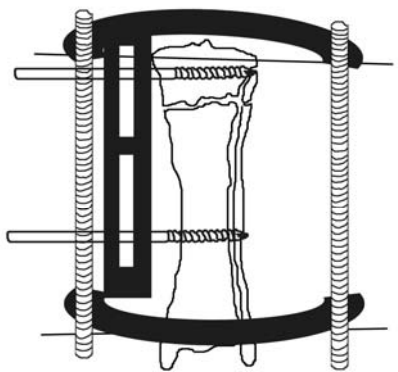

**8.** Insert a second pin with cranio-medial direction in the proximal fracture segment.

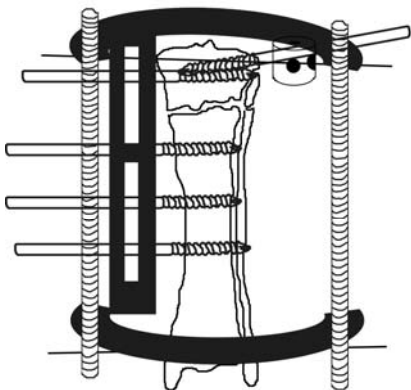

**9.** Stabilize the fracture by threaded pins inserted in each fracture segment as required to stabilize it. The pins in cranio-lateral direction should be put cranial enough not to transfix the cranial tibial muscle

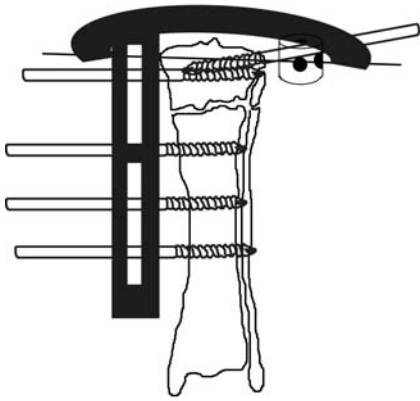

**10.** Remove the threaded bars and distal ring, leaving the hybrid construct. Consider using the sail-shaped stabilizing construct when required.

# **TRANS-ARTICULAR FRAME**

## TECHNIQUE FOR TIBIO-TARSAL TRANSARTICULAR FRAME CONSTRUCT



**1.** Once the appropriate procedure on the tarsal joint has been performed, measure the distance from the distal third of the tibia to the center of the tarsus. This will be the distance between the proximal ring and the hinge.

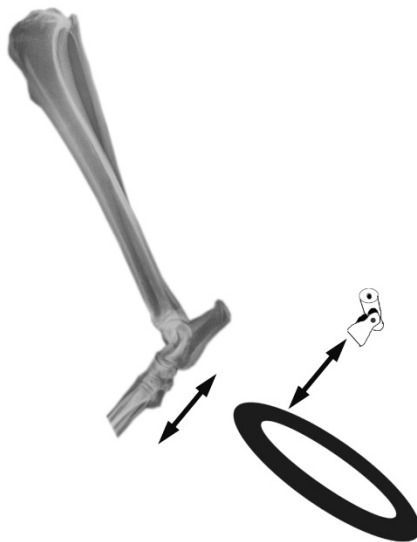

**2.** Measure the distance between the proximal part of the MTT bones to the center of the tarsus. This will be the distance between the distal ring and the hinge.

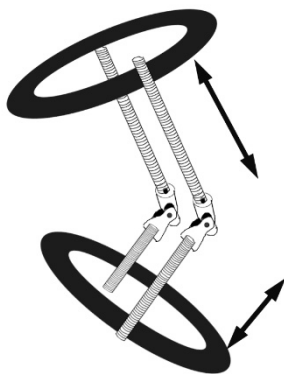

**3.** Preassemble the frame, connecting each side of the proximal ring to the distal ring by a proximal and a distal threaded bar. They should correspond to the first and second previous measurement, respectively. The bars should be connected by a hinge at their junction.



**4.** Once the frame is ready, autoclave it and it's ready to be used during surgery. Place the frame so that the hinge's axis (fulcrum of the frame) will be aligned with the axis of the tarsus.

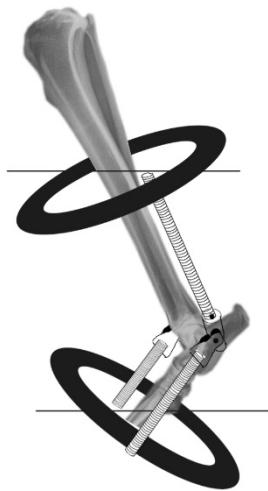

**5.** Stabilize the frame with the tarsus by just one K wire on the proximal and distal ring. Check the alignment of the hinges with the tarsus, flexing and extending the joint and evaluating that the frame is not displaced during the movement. If this occurs, you may need to change the position of the hinges.

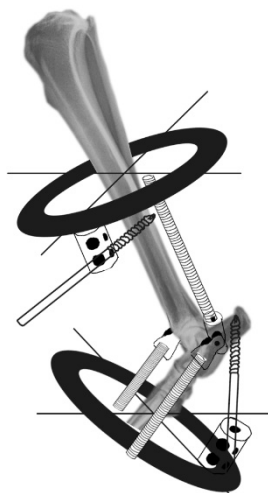

**6.** When you are satisfied with the correspondence of the movement of the frame together with the joint, you can add stability to the frame by further K wires and pins.



**BONE LENGTHENING**

**BONE TRANSPORT**

# TECHNIQUE FOR BONE LENGTHENING & TRANSPORT

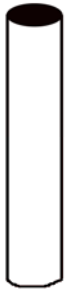

**1.** Bone lengthening: take the plastic pipe simulating the bone

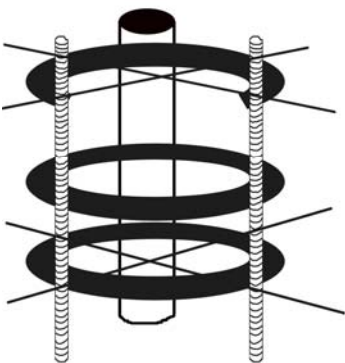

**2.** Construct a frame like the following one. Connect the proximal 3/4 ring and the distal ring to the bone, leaving the middle ring free. Be sure you have enough bar length left for distraction on the distal side of the frame.

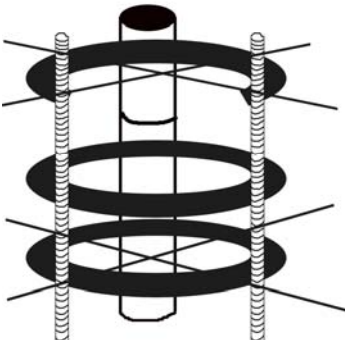

**3.** Perform the osteotomy in the desired position for lengthening.

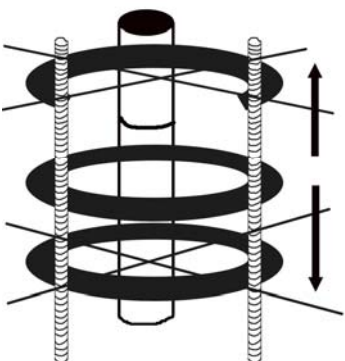

**4.** Apply distraction lengthening the threaded bars, acting on the nuts on the distal ring

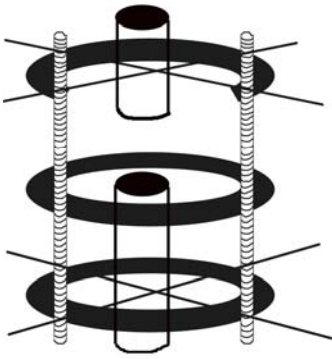

**5.** Check you achieve the distraction; note that the exceeding bars' length has been used for this, and the overall frame length increased

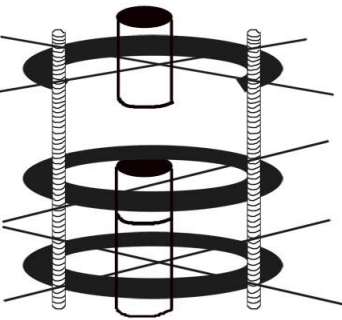

**6.** To start with bone transport: connect the middle ring to the bone, and perform an osteotomy distal to it, to obtain a bone cylinder for transport

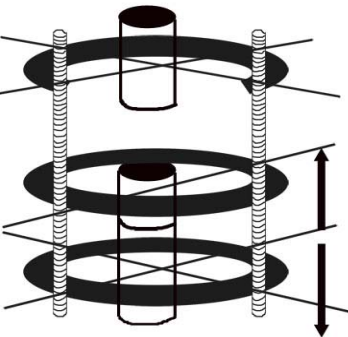

**7.** Apply distraction between the distal and middle rings, acting on the nuts on the middle ring

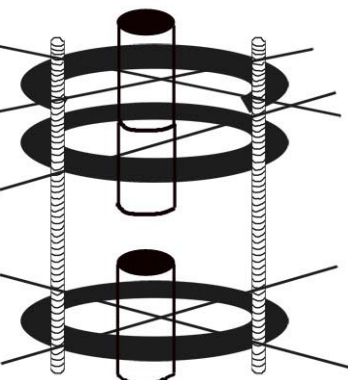

**8.** Perform the transport until you reach the proximal bone stump. Note that that the overall frame length stays the same

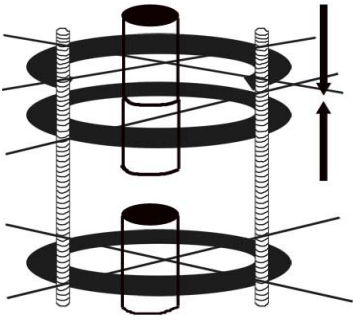

**9.** Perform compression at the docking site, if needed

# **MEASUREMENTS FOR ANGULAR DEFORMITY**

## **CORRECTION**

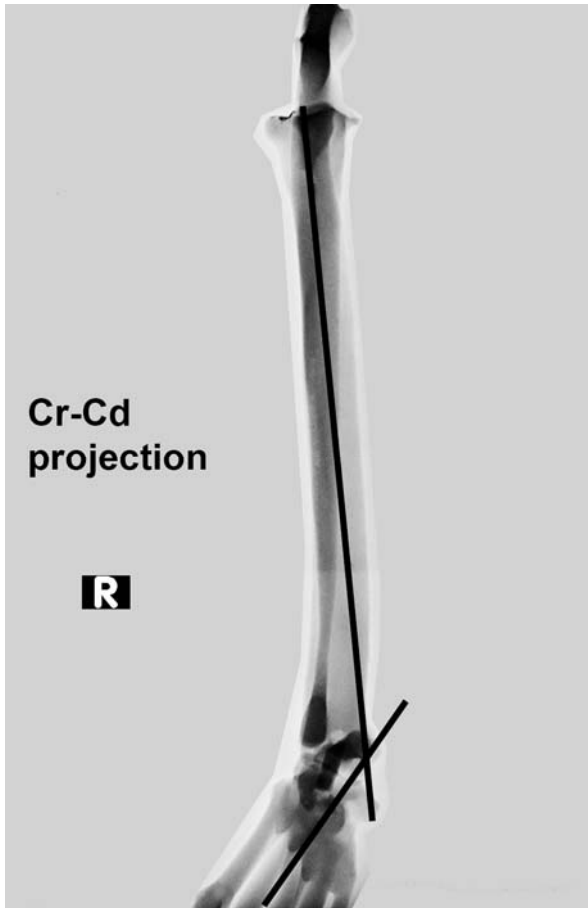

**1.** Measure the angle between the axis of the proximal and distal segments in Cr-Cd projection. This is the deformity on the frontal plane. In this example, the angle is  $42^\circ - 5^\circ$  of physiological valgus =  $37^\circ$  of valgus.

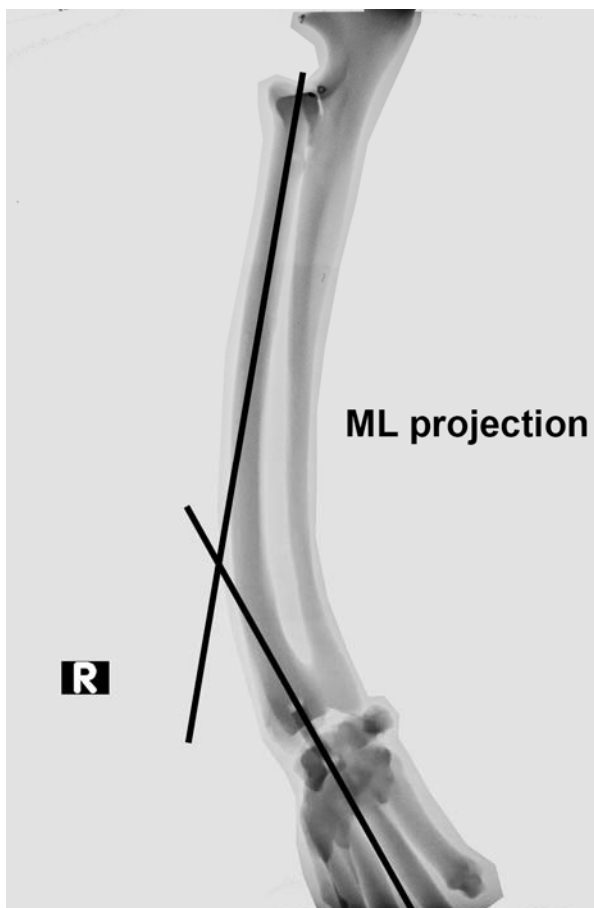

**2.** Measure the angle between the axis of the proximal and distal segments in ML projection. This is the deformity on the sagittal plane. In this example, the angle is  $39^\circ - 10^\circ$  of physiological procurvatus =  $29^\circ$  of procurvatus.

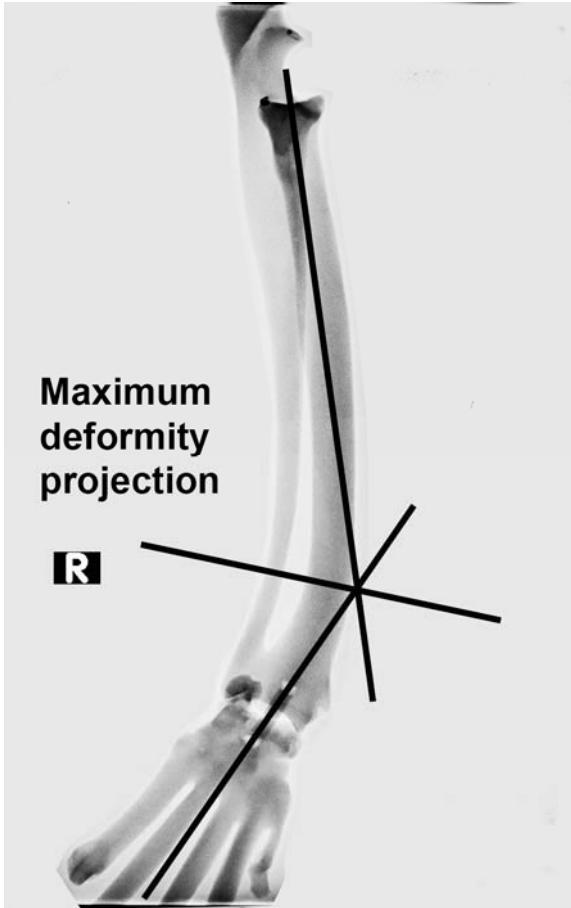

**3.** Measure the angle between the axis of the proximal and distal segments in MD projection. Draw the bisector of the angle: this is the plane of deformity. The hinges should be put on this plane tangent to the cortex.

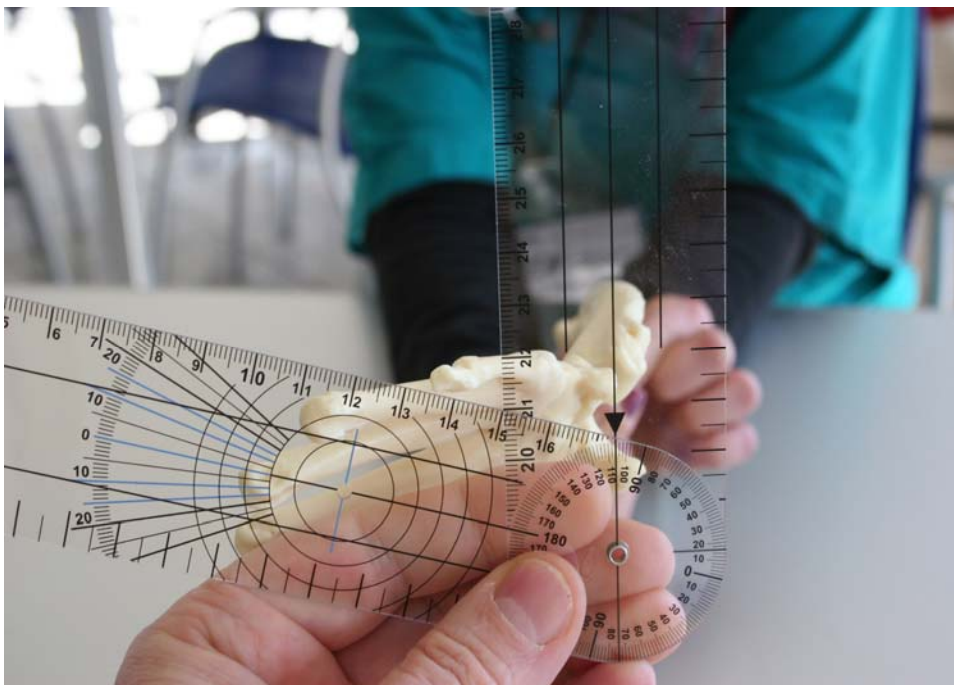

**4.** Measure the torsional deformity by flexing and extending the carpus, holding the elbow in the sagittal plane. In this example, 75°.

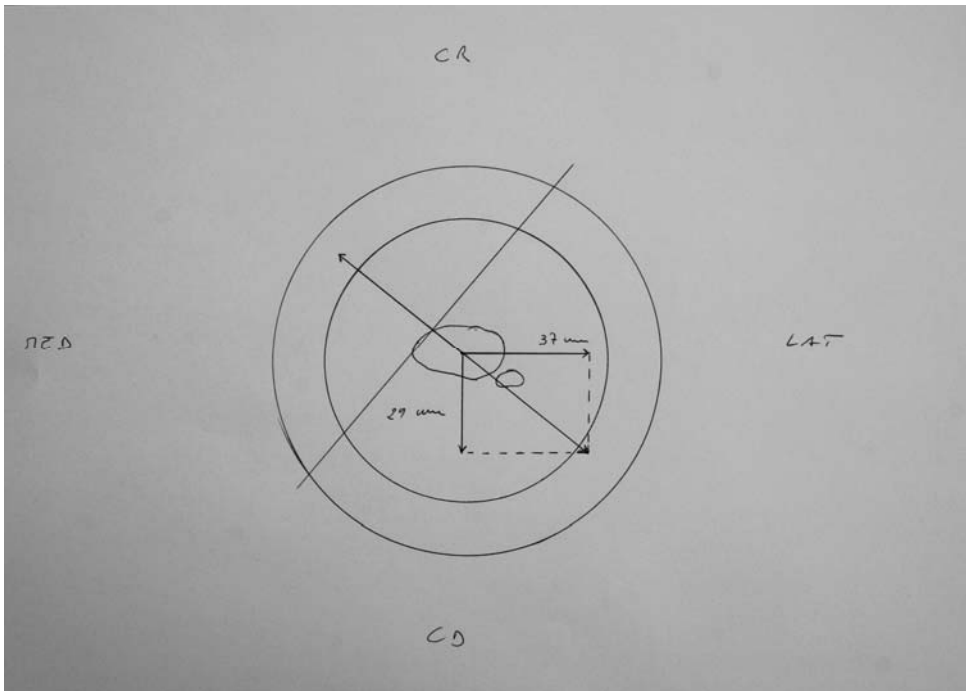

**5.** Draw the hinges' position on the ring using the registered data.



**6.** Set the distal ring following the drawing.





**7.** Set the proximal block up.



**8.** Connect the proximal block with the distal ring.

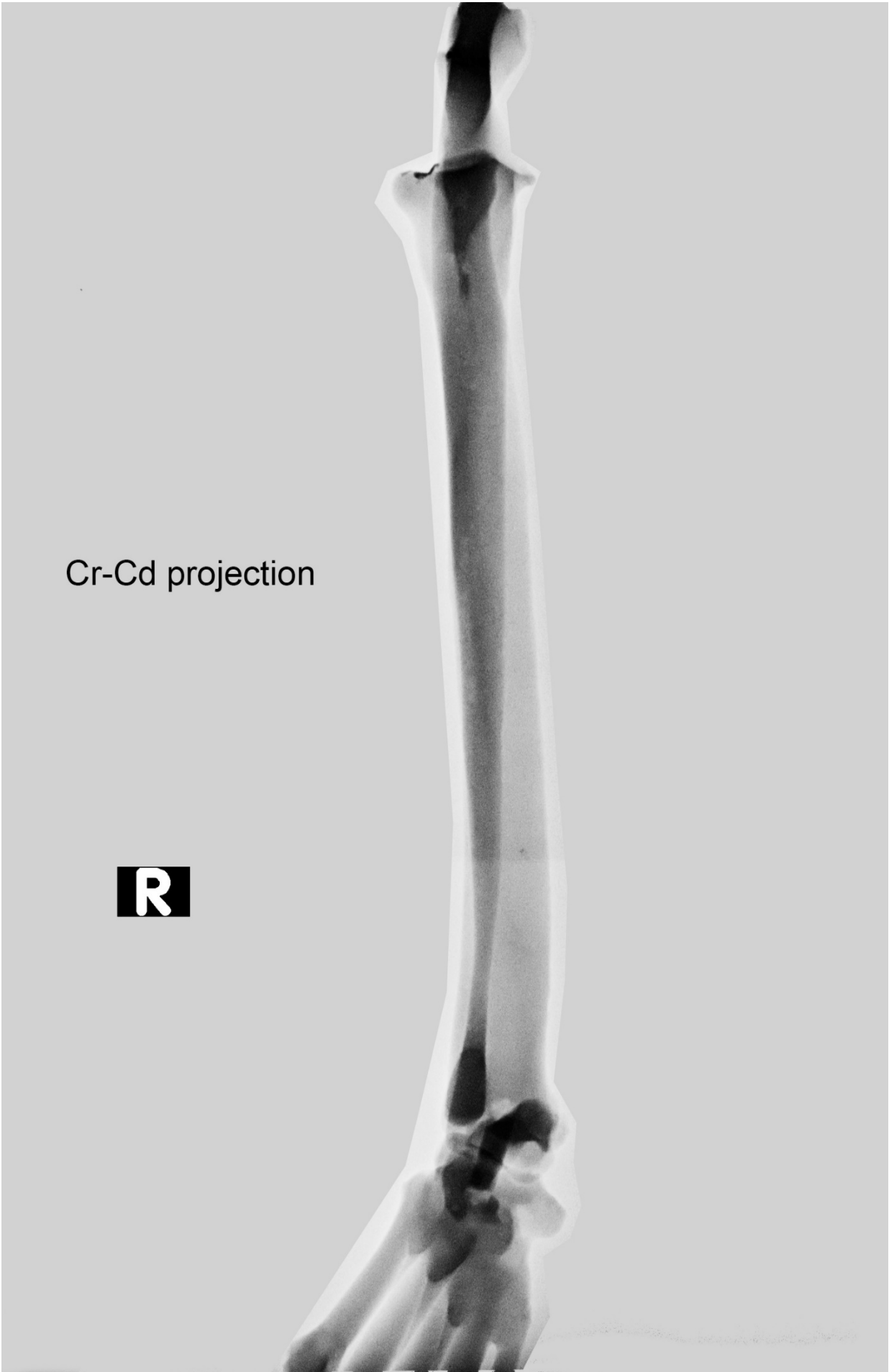

Cr-Cd projection

**R**

ML projection

**R**



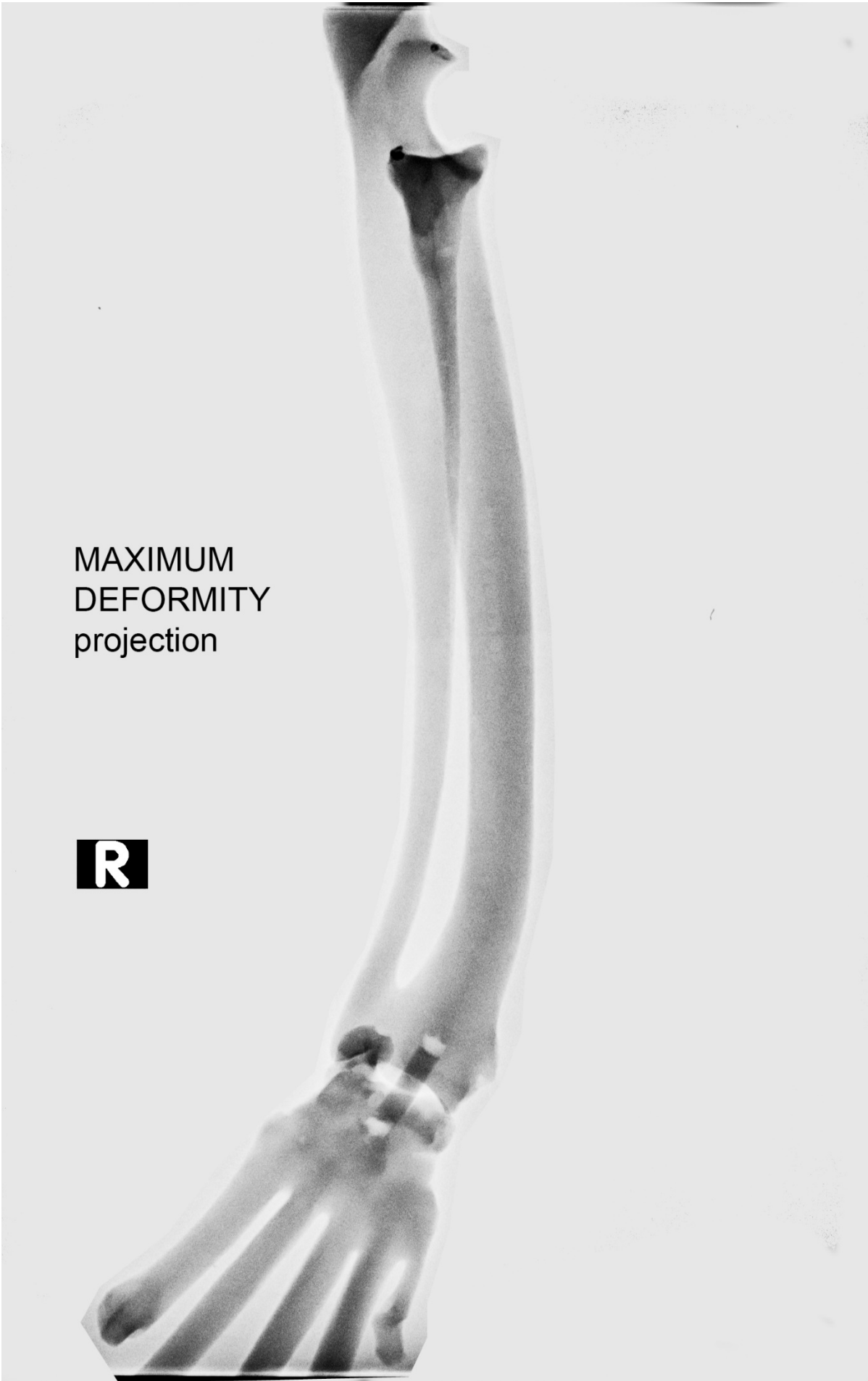

MAXIMUM  
DEFORMITY  
projection

**R**

The information provided in this manual is just for orientation, and should never be considered like a technical prescription.

The external fixation instruments and frames are medical devices, and should be used only by a trained surgeon authorized to their used.

The techniques described in this manual are intellectual property of Ad Maiora srl®, and cannot be reproduced in any way without the written consent of the company.

Ad Maiora srl

Via della Costituzione 10

42025 Cavriago (RE) - Italy

<https://www.ad-maiora.eu>

[info@ad-maiora.eu](mailto:info@ad-maiora.eu)

